

ATLAS VACUUM CHAMBERS

Leaders in Aluminum Vacuum Technology

Better Vacuum - Lower Cost - Better Results



Atlas Technologies / Catalog 11030



Atlas
TECHNOLOGIES

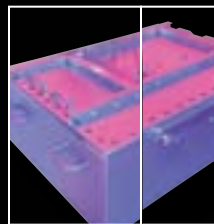
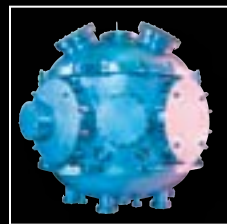
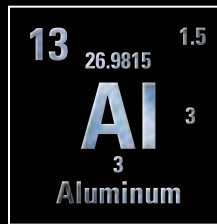

The Aluminum Revolution

Better Vacuum - Lower Cost - Better Results

The Aluminum vacuum revolution has started — In a remote corner of Washington State, in the rain shadow of the Olympic Peninsula, nestled along Puget Sound, Atlas Technologies has been driven to think beyond the convention of stainless steel.

First with the invention of the robust all-metal-seal Atlas CF flange and the Atlas ATCR fitting, Atlas made aluminum high and ultra high vacuum possible. Next, Atlas took on welding and surface preparation challenges. Now with Atlas' advanced UHV grade aluminum welds and surface oxide densification technology Atlas' aluminum vacuum chambers can easily outperform stainless chambers in any vacuum regime at a lower cost. It is time to say goodbye to stainless steel and *think in aluminum*.

Lower cost? Yes, the larger the chamber the better. Aluminum is half the price of stainless, machines 5 times faster and is 1/3 the weight. It also has lower outgassing and diffusion rates than stainless steel. This means better vacuum at lower prices when you *think in aluminum*.

There are five basic aluminum chamber configurations to choose from. Select the configuration that fits your need. Atlas, industry leaders in aluminum vacuum technology, offers full engineering support, FEA services and solid modeling design that capitalize upon the exceptional physical and vacuum properties of aluminum. Atlas will help you get the most out of aluminum. Since we already do — let us help you think in aluminum.

Atlas Technologies Aluminum Revolution Delivered

Atlas Vacuum Chamber Technology

Table of Contents

The Atlas Aluminum Revolution	2
Extreme Vacuum Performance Potential	
Extreme Vacuum Performance Delivered	
Atlas Aluminum Vacuum Chamber Configurations	4
Plate-to-Plate	Plate aluminum chambers
Cylindrical	Tube aluminum chambers
Formed	Spun / Formed aluminum chambers
Monocoque	Solid aluminum chambers
Extruded	Extrusion aluminum chambers
Atlas Aluminum Vacuum Chamber Engineering	6
Solid Modeling	
FEA Mechanical and Thermal Studies	
Final Design and Manufacturing	
Atlas Aluminum Vacuum Chamber Testing	7
Vacuum Integrity	
Chamber Testing Methods	
Assembly	
Inspection	
System Integration	
Atlas Customers and Testimonials	8
Industrial	
Government	
Academic	
Atlas Company Information	9
Orders, Payment Terms, Discounts, Shipping Charges, Prices, Specifications and Warranty	



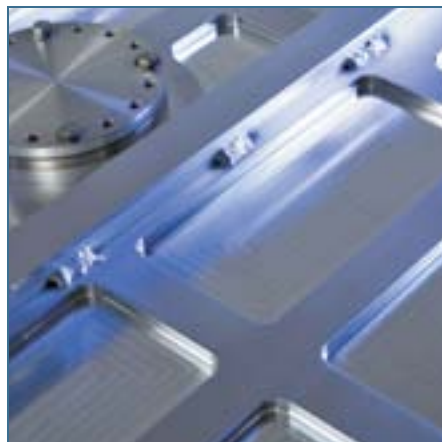

Aluminum's properties, when looked at in sum, offer many compelling physical and cost of ownership advantages over stainless steel.

Aluminum's Extreme Vacuum Performance Potential

Any single physical or chemical property of aluminum may be enough reason to select aluminum as a vacuum chamber choice over stainless steel. But when looked at in summary, aluminum overwhelmingly surpasses stainless steel as providing the lowest cost of ownership.

Aluminum has seven orders of magnitude less hydrogen than stainless steel. It has very low levels of Carbon, resulting in significantly less H₂O, CO, C₂ and CH₄ than stainless steel. Aluminum vacuum systems require far less pumping than comparably equipped stainless steel chambers. A baked aluminum chamber has an outgassing rate of less than 1x10⁻¹³ Torr liter/sec cm² compared to Stainless' 6.3 x10⁻¹¹ Torr liter/sec cm² ⁽¹⁾.

An aluminum chamber processed according to Atlas specification AVSP-08, entails cleaning and baking surfaces to facilitate the formation of a dense oxide passivation layer through the conversion of hydroxides into stable oxide molecules. The resulting surface inhibits the diffusion of other contaminants, further reducing pumping requirements—and faster pumping equates to smaller and less expensive pumps.

Fluorine gas is a common cleaning agent in aluminum chambers. Atlas aluminum chambers and gas delivery lines are far more resistant to fluorine than those made of stainless steel, because Atlas' AVSP-08 process forms a dense protective oxide layer that make our aluminum a highly corrosion resistant material. These surfaces can be further protected from halogens by producing even thicker and harder oxide layers through an electrolytic anodizing process.

Excellent thermal properties such as high conductivity make aluminum an excellent vacuum material. With 10x the thermal conductivity, 21x the thermal diffusivity of stainless and extremely low thermal emissivity rates, aluminum chambers bakeout quickly and evenly. The surface properties of aluminum allow full bakeout at 150°C — much lower than stainless. Aluminum chambers heat up quickly and uniformly, bakeouts are faster and more complete with significantly reduced cycle times.

With low nuclear activation, aluminum has a short neutron activated half-life measured on a scale of hours—significant when compared to stainless steel's scale, which is measured in thousands of years. This offers huge disposal savings and a priceless reduction in potential exposure to staff.

Aluminum is essentially magnetically transparent (non-magnetic). An aluminum UHV chamber's low magnetic permeability offers no measurable disruption to electron and ion optics.

With a low Young's' modulus (69GPa) of elasticity (1/3 that of stainless steel, 207GPa) aluminum offers outstanding vibration dampening, making it the material of choice for precision synchrotron, semiconductor and physics applications where excess vibration can have disastrous consequences.

Compact aluminum vacuum chambers with up to 40% smaller footprints are economical alternatives to bulky stainless steel systems, especially when valuable floor space is at a premium. At about 1/3 the weight of stainless steel, aluminum chambers are significantly lighter and require less expensive support structures. Lower weight translates into reduced shipping costs and faster installation times.

Because of its superb machinability (5x to 10x faster than stainless) aluminum chambers can be manufactured with more detail. Aluminum can also be cut, shaped or formed, and extruded quite easily. Chamber features are produced to fit an application rather than tailoring an application to fit a material's manufacturability limitations—reducing extra equipment and space.

Atlas offers five basic aluminum chamber types... monocoque, plate, tube, extruded and formed aluminum configurations, to give you a variety of design options and complete control of your application.

After weighing all factors, Atlas aluminum vacuum chambers can save 40% to 60% when compared to stainless—and the bigger the chamber, the more pronounced the savings—plus when fitted with Atlas CF Flanges, ATCR fittings and treated with AVSP-08, cost less than comparably equipped stainless systems. Cost savings are directly attributed to

aluminum's machinability; reduced outgassing volume and surface area; fast cycling, bakeout and pump-down times; reduced footprint and smaller/lighter support structures; reduced shipping cost; and lower disposal costs when dealing with nuclear activation applications.

Aluminum's Extreme Vacuum Performance Delivered

Atlas has overcome the three major obstacles that have inhibited the use of aluminum in extreme vacuum applications... *vacuum sealing, vacuum welding and vacuum surface passivation*. Applying our knowledge and proprietary technology we produce state-of-the-art aluminum vacuum chambers that deliver the revolutionary physical and vacuum properties of aluminum at dramatic cost savings.

Atlas Vacuum Surface Passivation (AT-VSP) — Aluminum is produced with a heavy mill scale and rough (porous) oxide layer—a surface not well suited for vacuum, because it absorbs water vapor and other contaminants. After removing this rough layer Atlas cleans all metal surfaces before, during and upon completing the fabrication process. Atlas' Advanced Vacuum Surface Passivation (AT-VSP) replaces thick porous oxide layers with a quality thin and dense oxide surface. Atlas' AT-VSP-08 specification establishes a standard for the creation of dense oxide surface passivation. Treating aluminum in this manner effectively reduces surface area, contamination and desorption.

Atlas Advanced Vacuum Welding (AT-AVW) — Even to experienced welders, the welding of aluminum to vacuum standards is a challenge many are not capable of achieving. The welding process can introduce porous oxides that impede hermetic welding. In other industries these welds can meet mechanical standards, but when tested to vacuum helium leak standards are considered inadequate. Atlas aluminum vacuum welds are quite distinctive from conventional aluminum welds. They are more continuous, have a 'glassy' surface and minimized area. Atlas' AT-AVW process reduces internal and external oxide inclusions, effectively eliminating leak paths or virtual leak pores—essential to good vacuum performance. Typically the AT-AVW process produces a smaller heat affected zone, which leads to less surface haze and contamination.

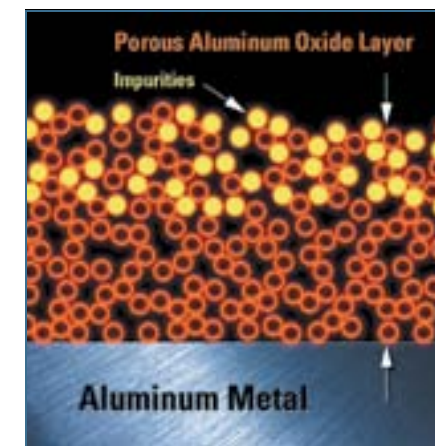

Aluminum oxide condition as received from metal supplier.



Aluminum oxide layer after conditioning metal with Atlas' proprietary AVSP-1 process.

Vacuum Sealing (AT-ISO, AT-CF, AT-CR) — Atlas manufacturers all standard aluminum demountable vacuum flanges and fittings. These flanges are welded to an aluminum vacuum chamber giving access its interior. ISO quick-release and clamped / bolted style O-ring sealed aluminum vacuum flanges (AT-ISO) are the most common standard high vacuum fittings. To achieve higher vacuum levels (UHV), metal seals are required, but aluminum is soft and unable to crush copper or nickel gaskets. The Atlas AT-CF Flange and Atlas AT-CR fitting are metal seal components made by bonding a hardened knife-edge or gland sealing surface to an aluminum demountable flange or fitting body. These flanges and fittings are available in all standard sizes and configurations for weld-up to aluminum chambers and gas delivery lines.

Advanced Machining Capability — The machinability of aluminum is legendary. Atlas has invested in a 'state of the art' manufacturing facility that supports small to very large scale, single and multiple unit quantity, aluminum vacuum chamber fabrication. The bigger the chamber; the more economical aluminum can be. In addition to chambers, Atlas can also manufacture internal components, ensuring that an entire assembly is produced on time and to strict vacuum standards. When Atlas manufactures internal components its easier to keep focus on the end goal, the vacuum system's ultimate performance, ensuring that the system will perform as designed.

Vacuum System Test and Qualification — Atlas vacuum chambers are fully leak tested and vacuum qualified. With clean

assembly and test facilities Atlas can provide complete bakeout and residual gas analysis (RGA), vacuum leak-up, reverse pressurization and other qualification procedures. Atlas has multiple helium leak-test stations to maintain a high through-put. Atlas also offers clean assembly for internal vacuum components and devices. This saves you time and ensures that a chamber performs as designed. A chamber is not complete until it meets the Atlas minimum vacuum leak rate standard of 1x10⁻⁹ Torr liter/sec. Atlas can meet higher vacuum test standards if required.

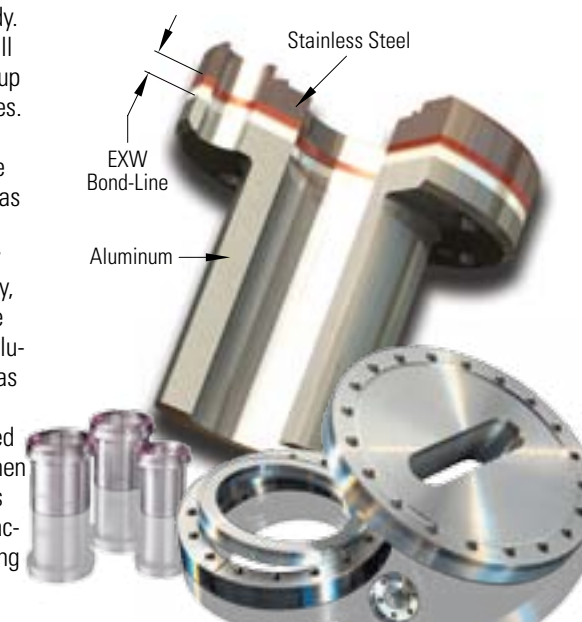

Atlas CF Flange™ and Atlas ATCR Fitting™ — The aluminum flanges and fittings with stainless steel knife-edge and face seals — they make aluminum UHV systems a reality!

Why choose Aluminum?

- Low Outgassing
- Low Contamination
- High Thermal Conductivity
- High Vibration Dampening
- Superb Machinability
- Space and Weight Reduction
- Low Nuclear Activation
- Low Magnetic Permeability
- High Chemical Resistance
- Low Cost of Ownership

⁽¹⁾ Chen, J.R. et al. *Thermal Outgassing from Aluminum Alloy Vacuum Chambers*. *Journal of Vacuum Science and Technology A* 3, p. 2188.

⁽²⁾ O'Hanlon, John. *Ultrahigh Vacuum in the Semiconductor Industry*, *Journal of Vacuum Science and Technology A* 12, p. 921.

Atlas Vacuum Chamber Configurations

Atlas Technologies is the world leader in aluminum vacuum chamber engineering and manufacturing. With over 30 years experience in cutting-edge vacuum product design, we pride ourselves in providing the world's finest and most advanced UHV aluminum chamber technology. Atlas' aluminum vacuum chamber production techniques (Chamber Configurations) can be broken down into five basic categories:

- Plate-to-Plate Chambers
- Cylindrical Chambers
- Formed Chambers
- Monocoque Chambers
- Extruded Chambers

We build custom aluminum vacuum chambers employing these configurations, or combinations thereof. We also manufacture and supply a wide range of aluminum vacuum components and accessory hardware to complement our aluminum vacuum chamber products offering. Bimetallic Atlas CF Flanges and AT-CR Fittings, solid aluminum tube fittings as well as viewports are available. Contact our sales department for more information on these and other Atlas products.

Plate-to-Plate



Plate-to-Plate chambers are constructed using aluminum alloy 5000 and 6000 series stock aluminum plate. Chambers manufactured by this technique can be very large. Unlike stainless steel, Aluminum plate is available in very large areas. Off the shelf plate can be 48" or 60" x 144". Atlas can supply even larger plates and chambers made from materials joined together by Atlas. Plate thicknesses are selected according to vacuum deflection calculations. Large rectangular O-ring sealed access doors or polycarbonate windows can be included in the design.



Cylindrical



Cylindrical chambers can be fabricated from standard off-the-shelf tube and pipe, or custom diameter aluminum roll-ups. An extensive selection of standard tube wall thicknesses is available. Tube and pipe wall thickness will be according to the diameter and schedule selected. Custom roll-up chambers are made from aluminum plate and are typically 5000 series aluminum alloy. All cylindrical chambers can be made with minimum wall thicknesses because of the inherent strength offered by tubular geometry.



Formed



Hemispherical Spun/Formed chambers are usually made from 5000 series aluminum alloy. These chambers offer minimum internal surface area and radially mounted flange axes converge and focus to a central or strategic target point inside the chamber. Spun chambers can be very large—and size is only limited by spinning/forming equipment capacity. These chambers offer maximum strength and minimum wall thickness.



Monocoque



Monocoque chambers are machined from solid aluminum alloy 5000 and 6000 series billet or thick plate. Forged material is often used to eliminate the risk of vacuum leak paths entrapped by the billet forming process—other methods can use cast micro-structure aluminum. Aluminum is available in extremely thick plates (40" or 1016mm). Monocoque chambers enable internal and external machining, which can provide a high concentration of design features, a minimum surface area and a maximum surface quality without weld oxide contamination. Precise component location is achieved, because these are controlled in a single machining setup and welding related distortion can be eliminated. Elaborate internal mounting brackets and shapes can be included in monocoque chamber designs.



Extruded

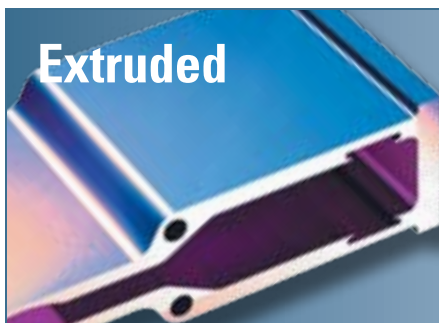

Extruded chambers are typically used for long chamber applications. However, intricate internal and external shapes can be economically added to other chamber types. Many synchrotrons require multiple chamber sections, each measuring between 4 to 8 meters in length. Extruded aluminum fabrication is ideal and has been used for these applications, because of cost and aluminum's ability to handle high heat loads and its resistance to photo-desorption of surface gases.

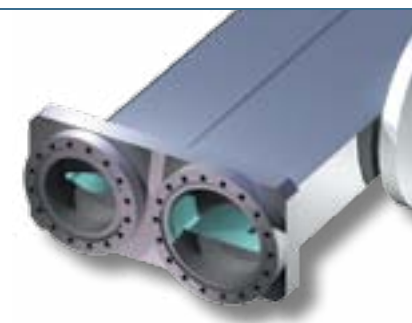

Atlas Vacuum Chamber Configurations

Atlas Vacuum Chamber Configurations

Above, aluminum chamber built using several Atlas manufacturing techniques... formed (spun) top and bottom hemispheres, cylindrical main body (roll-up) and tubular ports sealed with AT-CF and AT-ISO flanges.

Bellow, aluminum box-chamber built using plate-to-plate and monocoque chamber manufacturing techniques. Some typical Atlas chamber features (pictured in background) include Atlas glass viewports, polycarbonate covers, flush-mount AT-CF flanges and built-in (machined) monocoque chamber features.

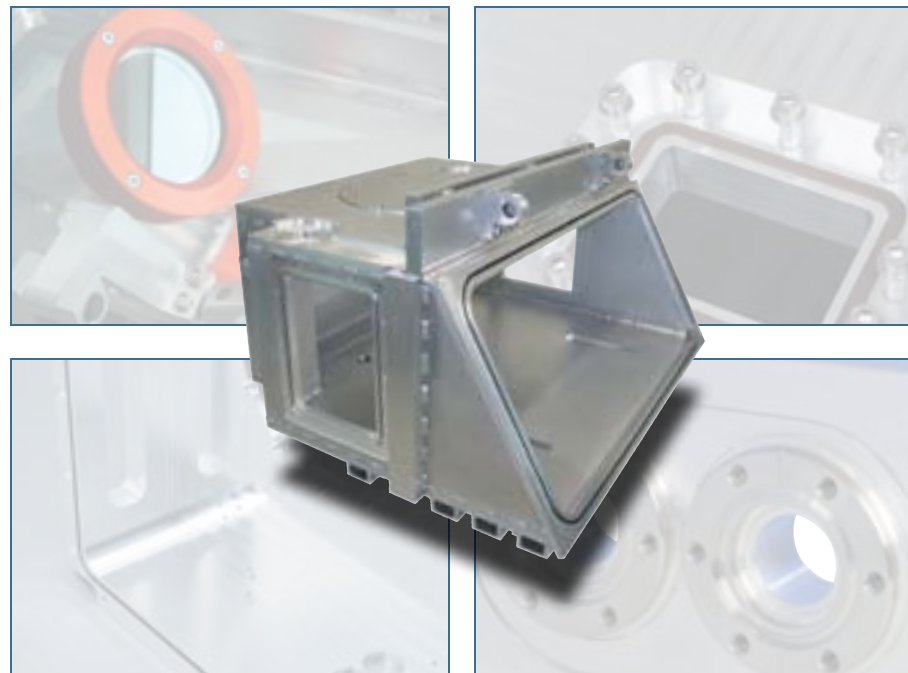

From Concept to Finished Product

At Atlas we employ the latest 3D-CAD modeling, finite element analysis (FEA) and vacuum software tools for the design, manufacturing and integration of our aluminum HV and UHV chambers and components. We are equipped to handle just about any modeling format in the industry. Send us your requirements in 2D or 3D CAD formats, or sketch on a napkin and fax—we'll bring your ideas to life.

Atlas will recommend the best fabrication method and chamber configuration to suit your application while considering performance, delivery and cost.

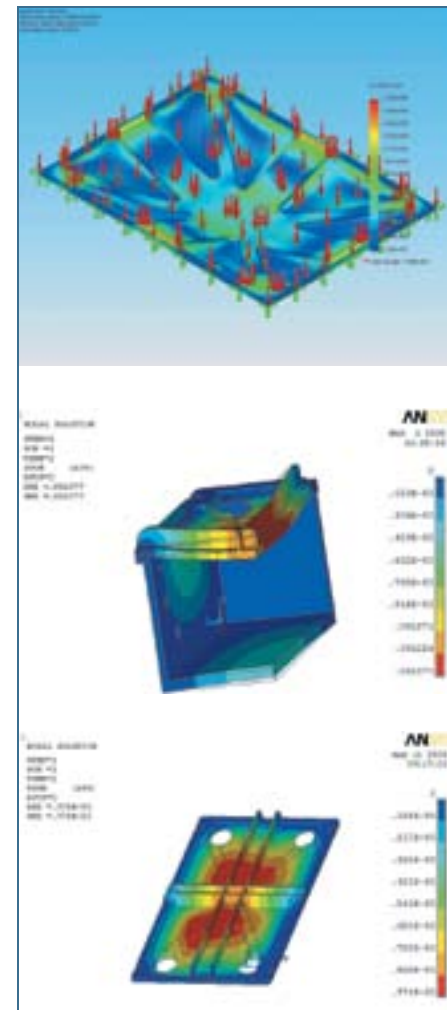

We use Finite Element Analysis (FEA) to assist in the optimal design of vacuum chamber components.

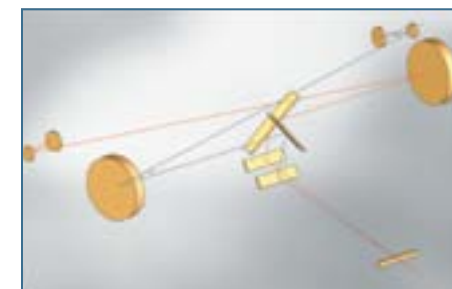

Atlas begins the design process with your fundamental layout requirements.

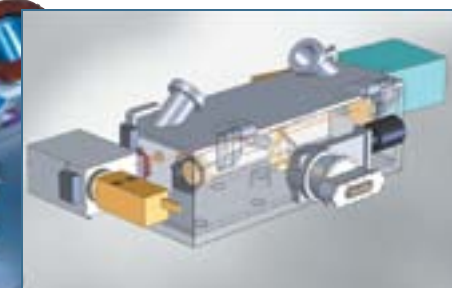

We build a solid model and produce a preliminary chamber design for customer review.

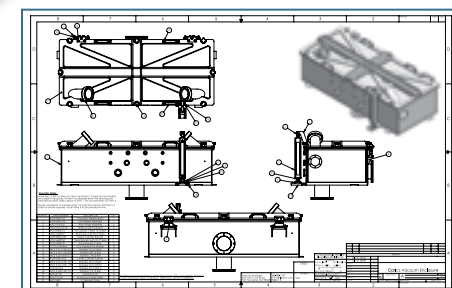

We complete final design and build the chamber



The completed chamber is tested, inspected and shipped to the customer.

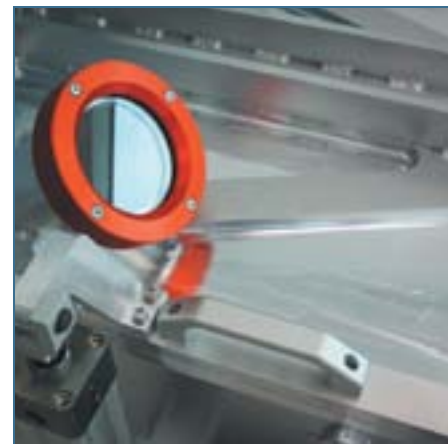

Atlas design and engineering at work for you.

Atlas Design & Engineering

- Solid Modeling
- FEA Mechanical & Thermal Studies
- Final Design & Manufacturing



System Integration — Atlas can assemble an entire system including chamber, frame, pumps, gauges, valves, manipulators and other components to your specifications in our 1000 ft² dedicated assembly area. After completion our technicians can perform thorough system qualification tests, including bakeout, RGA scan and leak check. A functional test is performed on all system hardware.

Assembly — Many vacuum chambers require assembly of components within. It is often economical for Atlas to supply a fully assembled vacuum chamber. Our assembly technicians can tackle assemblies ranging from the very simple to complex and consist of parts either manufactured in the Atlas factory, purchased, or customer supplied.

When we perform your assembly work we're able to prove out the design and also modify either the chamber or the assembly should fit or interference conflicts arise. Solving these issues at Atlas can prevent damage or contamination upon subsequent disassembly. Our assembly technicians also perform in-situ vacuum testing with assembly component installed.

Dimensional Inspection — Documentation and full dimensional tracking are integral to the Atlas manufacturing process. These documents are available to you upon your request. Please contact us if you would like to receive such documentation.

Chamber Frames — Atlas will routinely manufacture chamber mounting frames. As with our chamber manufacturing, we can either build frames per your design or design them for you. Well designed frames will integrate many required features to simplify chamber operation. For example, pumping ports may be mounted below the chamber, manipulation ports on top, load-lock port on the side with loading rails or booms all mounted to frame. Frames can be constructed of nearly any material—typically they are aluminum, stainless steel or powder painted steel.

We recommend casters with locking wheels with separate leveling pads. Given the breadth of design variation we recommend that you contact us so that we may work out a solution that will specifically address your requirements.

Atlas Vacuum Chamber Testing

Chamber Testing Methods — Atlas can provide nearly any vacuum chamber test you might require:

- Helium Leak Test
- Residual Gas Analysis (RGA) Scan
- Leak-Up Calculation
- Vacuum Qualifying: Low Vacuum ~ Ultrahigh Vacuum (UHV)
- Full Bakeout Capacity
- Positive Pressure Testing
- Exterior Helium Sniffing
- Vacuum Deflection Calculation
- Vacuum Surface Analysis

Vacuum Integrity — Every component and subassembly is helium leak tested to ensure vacuum integrity. The tested sub-components are welded to make a finished chamber. The final chamber assembly is helium leak

tested. With multiple leak check stations we are able to quickly and efficiently inspect and certify the vacuum integrity of your chamber. Standard practice here at Atlas is to test chambers to meet minimum sensitivities of 1x10⁻⁹ Torr liter/sec. As required we can test to higher or lower sensitivities per your specification.

Our extensive testing of aluminum vacuum chambers has given us the experience to know that ultimate vacuum pressure for large Atlas aluminum chambers can reach UHV levels in less than 24 hours after exposure to atmosphere!



Helium mass spectrometer leak testing and RGA underway in our QC department.

Atlas Quality Standards

- Vacuum Integrity
- Chamber Testing Methods
- Assembly
- Inspection
- System Integration

Atlas is proud to partner with these quality manufacturers



Please contact us regarding future projects

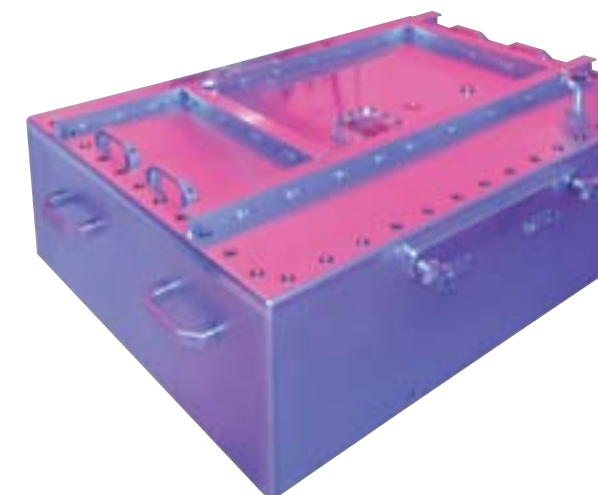

Atlas Customers

The Atlas customer base consists of a wide and diverse grouping of industrial, government, academic and scientific entities located around the globe.

Our primary areas of business include Semiconductor, FAB, Solar, Particle Physics, Synchrotron, Nuclear Medicine, Cryogenic and Neutron Radiation disciplines, and many others. For your reference, the following is a partial list of Atlas customers:

Industrial Customers

- Applied Materials, USA
- Novellus Systems, USA
- Durex, USA
- General Atomics, USA
- General Electric, USA
- Lucent Technologies, USA
- Sencera Solar, USA
- Ovonic ECD, USA
- Tokyo Electron, USA
- Oxford Instruments, United Kingdom
- Ulvac, Japan
- Beneq, Finland
- Advanced Cyclotron, Canada

Government Customers

- ANL, Argonne National Lab
- BNL, Brookhaven National Lab
- CAMD, Louisiana State University
- FNL, Fermi National Lab
- JNL, Jefferson National Lab
- LANL, Los Alamos National Lab
- LBL, Lawrence Berkeley National Lab
- LLNL, Lawrence Livermore National Lab
- NASA, National Aeronautics & Space Administration
- SLAC, Stanford Linear Accelerator Center
- BESY, Germany
- CERN, Switzerland
- KEK, Japan
- ESRF, France
- DESY, Germany

Academic Customers

- Louisiana State University, CAMD
- Ohio State University
- University of Texas
- University of California, Berkeley
- Stanford University
- University of Rochester
- University of Wisconsin
- University of Washington

Customer Testimonials

"During my tenure at Ovonic ECD (United Solar) I was very pleased with the service and quality we received from Atlas Technologies.

Before working with Atlas all of our thin film photovoltaic production line was manufactured out of stainless steel. Atlas assisted us in converting the drive and transition chambers to aluminum; this created a substantial (50 to 60%) cost savings.

By using the standard weld-on bimetallic Atlas AT- CF flanges we were able to eliminate O-rings and reduce contamination. The quality of the chambers and equipment we have received from them has been exceptional. Furthermore when we commission their chambers it has become worry-free for our installation crews.

We maintain a very aggressive production schedule and they have always been accurate, up-front and on time with their delivery commitments. They also price themselves



aggressively. I strongly recommend Atlas Technologies for future work"

George Uzoni

*Formerly, Design Supervisor
Energy Conversion Devices (United Solar)*



"We have been working with Atlas for many years using their Atlas CF flanges and explosion bonding capability for assemblies such as beryllium windows. In 2005 we had a need for a dipole magnet vacuum chamber. Atlas competed with vacuum equipment manufacturers worldwide and won the bid, beating out stainless steel vendors in Europe and Russia by a large margin.

This is a large chamber ~2.9 m long with two 50 mrad acceptance aperture IR beamlines tangential to the synchrotron electron beam

orbit. All flanges including e-beam orbit, synchrotron radiation ports and pumping ports were fabricated from Atlas CF flanges. In addition to the demanding geometrical constraints of the dipole magnet the chamber was required to absorb all excess synchrotron radiation not entering the beamlines and resist any deformation due to forces incurred under vacuum. Atlas presented a preliminary design for approval before fabrication and conducted a complete FEA analysis of the chamber studying both the thermal loading and the vacuum deflection.

Atlas fabricated the chamber in two halves with each half having a water cooling surface machined into the chamber. The two halves were welded together and final machining brought the chamber overall thickness tolerance and chamber radius of curvature tolerance to less than 1mm. The chamber is presently installed in the CAMD synchrotron in bending magnet 2 and attains a base pressure less than 5 x10⁻¹⁰ Torr without bakeout"

Research Associate Engineer

*Engineering Support Group
A USA Academic Synchrotron*