

## **HOMC3000-series XY Manipulators**

***With 8.0" (CF150) Flanges***



**Include  $\pm 2^\circ$  tilt adjustment on the top flange**

The **HOMC-series** of XY translators combine extremely high rigidity, a large working bore and affordable cost.

They are available in both  $\pm 1.0$  ( $\pm 25$  mm) and  $\pm 0.5$ " ( $\pm 12.5$  mm) travel, circular pattern with both manual and stepper motorized versions. In fact, conversion from micrometers to stepper motors can be done in 15 minutes at the user's site.

The entire MC-series ranges in size from the very large MC3000 shown here have features not found on translators available elsewhere. These include  **$\pm 2^\circ$  tilt adjustment** on the top flange, and the ability to mount the X-axis micrometer (or motor) on *either side*, which are standard

### **Expandable**

One distinct advantage of the **HOMC3000** is the cost savings when long Z Axis strokes are required. Since only the bellows in the XY portion needs to be larger than the probe, the user can extend the Z Axis stroke using a smaller diameter (less costly) bellows that just clears the probe running through it. Simply select the model below that best suits your needs. Custom configurations are also available.

For horizontal mounting, i.e., with the flange faces vertical, dual constant force counterbalance springs are available that compensate for gravitational loads. If required, this feature can be added **in the field**, after the user accurately determines the weight of the devices to be mounted.

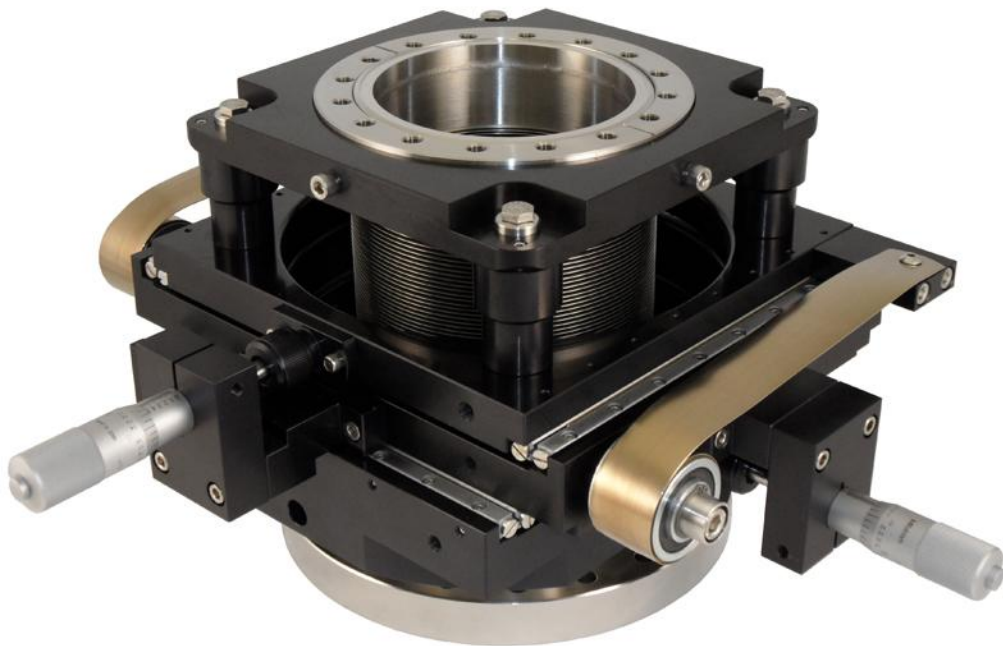

To make your selection, add the total travel required in either the X or Y axis to the **maximum** diameter of the device that will pass through the **HOMC3000**. This sum determines the **minimum** bellows inside diameter (ID).

Next, select the bottom flange that best mates to your chamber or other equipment. While the most common size is 8" OD (CF150), either tapped or non-tapped flange sizes of 10" (CF200), 12" (CF250) and larger are available. Consult the factory for more information.

### **Payload**

The top flange carries the 'payload' of whatever is mounted on it and also carries an atmospheric load of approximately 230 Kg for the MC30 series. This flange can be adjusted up to  $\pm 2^\circ$  to compensate for any slight misalignment of chamber flanges or installed devices.

## Ordering Information

Model	X-Y Travel	Clear ID	Height*	Ship Weight
HOMC3000-1.6	± 0.5" (12.5)	5.87" (150)	7.0" (178)	56 lbs. (26 Kg)
HOMC3000-2.6	±1.0" (25)	5.87" (150)	8.4" (213)	58 lbs. (27 Kg)

Dimensions are in inches (mm)  
Flanges are **not threaded**, unless specified otherwise

## Options

- 1) Reduce height by 0.5" (12.7) for each tapped flange (small price!)
- 2) Horizontal Mounting Kit,
- 3) Stepper motors ,
- 4) Stepper Motor Controller (first axis),
- 5) Additional Axes (may be combined - consult factory),

## Drawing

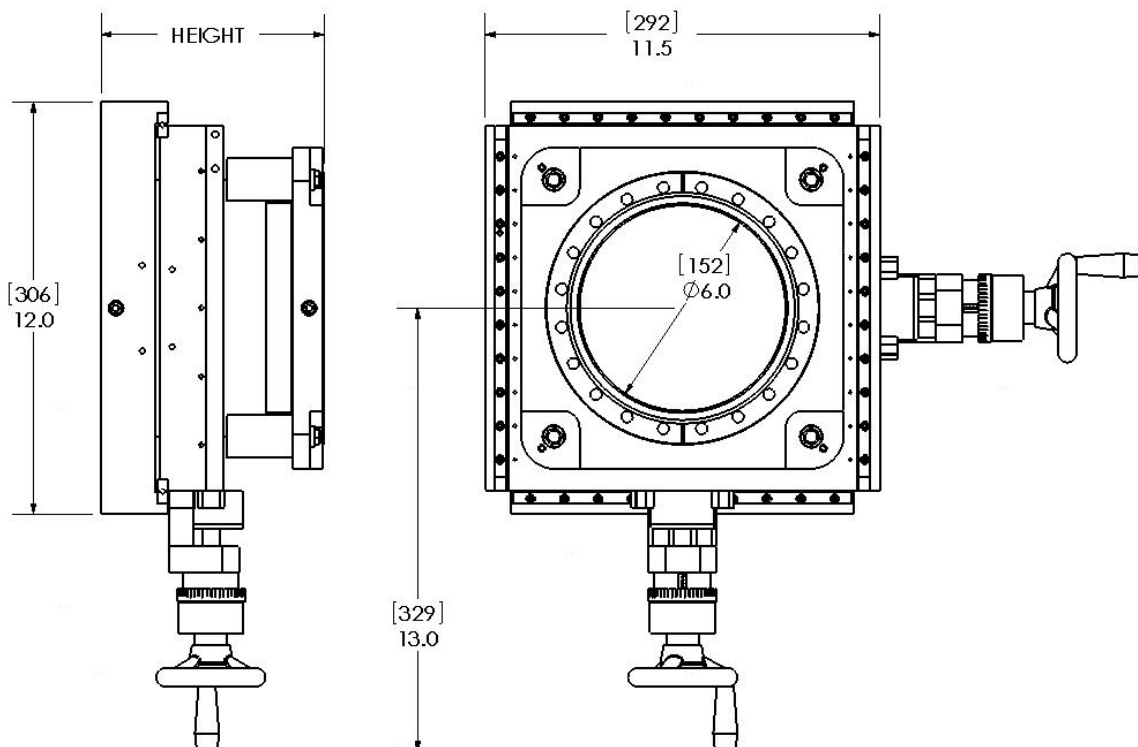

## Circular Pattern vs. Square Pattern

XY Manipulator motions are defined as either **Circular Pattern** (sometimes called **Vector Sum**) or as **Square Pattern**.

For example, a manipulator with a  $\pm 0.5"$  ( $\pm 12.5$  mm) of XY travel, **Circular Pattern**, will move the center of the translated device anywhere within a 1" (25 mm) circle, as shown in the graphic, below. Note that the radial offset (the sum of the vectors) will remain constant while the individual X and Y offsets vary. For a manipulator with  $\pm 1.0"$  ( $\pm 25$  mm) of XY travel, **Circular Pattern**, the values will be twice that of the  $\pm 0.5"$  ( $\pm 12.5$  mm) values but the relationships will persist.

Unless specified otherwise, **all manipulators**, as well as **all** other manufacturer's manipulators are circular pattern. Also, the minimum bellows ID **must** equal twice the radial offset **plus** the diameter of the device to be translated. Be sure to keep this in mind when specifying a manipulator.

A manipulator with  $\pm 0.5"$  ( $\pm 12.5$  mm) of XY travel, **Square Pattern**, will move the center of the translated device anywhere within a 1" **square** so that when both the X and Y orthogonal offsets are at 0.5" (12.5 mm), the bellows is **actually** offset 0.707" (18 mm). As above, for a manipulator with  $\pm 1.0"$  ( $\pm 25$  mm) of XY travel, the values will be twice that of the  $\pm 0.5"$  ( $\pm 12.5$  mm) values, but the relationships will persist.

