

INNOVATIVE
FLOW & PRESSURE
SOLUTIONS

PRODUCT & TECHNICAL
GUIDE



ALICAT[™]
SCIENTIFIC

FINALLY, FLOW INSTRUMENTS THAT LAST A LIFETIME!

All Alicat[™] measurement and control products come with a **LIFETIME WARRANTY!**

Alicat[™] Instruments — Simply the Most Standard Features

- ▶ Four instruments for the price of one! Mass flow, Volumetric flow, Pressure & Temperature.
- ▶ Control pressure while monitoring mass flow!
- ▶ Fast: ≤ 50 millisecond control response (typical).
- ▶ Accurate: ± (0.8% of reading + 0.2% of full scale) standard.
± (0.4% of reading + 0.2% of full scale) available for most units.
- ▶ Instant on. No warm-up required.
- ▶ Gas Select[™] with 30 field selectable gases, No charts to reference.
- ▶ RS-232 or RS-485 & Analog Input/Output. Also available — PROFIBUS or DeviceNet.
- ▶ Multiple drop capable RS-232 or RS-485.
- ▶ Stand-Alone control.
- ▶ Simple, position insensitive installation.
- ▶ No straight runs of pipe required!
- ▶ Low sensitivity to ambient pressure and temperature changes.
- ▶ Operate on standard 12-24 Vdc (±15 Vdc not required).
- ▶ Full function LCD display (Backlit multi-color TFT display optional)
- ▶ Support a wide range of options without extra software or components.



Alicat provides quick delivery — Typically 10 days from receipt of order.

Alicat promises full technical support and low cost recalibration with quick turnaround.

Alicat products are supplied with NIST traceable certification and carry the CE mark.

Call or visit us online for orders and more information.

FIND YOUR FLOW AND PRESSURE SOLUTIONS AT ALICAT[™] TODAY!

ALICAT RAISES **CUSTOMER SERVICE** TO THE HIGHEST LEVEL

IF YOU CAN ENVISION IT, WE WILL DO OUR BEST TO BUILD IT



WE WILL MODIFY OUR PRODUCTS TO FIT YOUR NEEDS
IN THE MOST **TIME EFFICIENT AND COST EFFECTIVE**
MANNER IN THE INDUSTRY

OUR SUCCESS IS BUILT ON YOUR SATISFACTION

Alicat Scientific has been designing and manufacturing precision instruments since its beginning in 1991. We believe our success is due to more than just selling great instruments but to our policy of providing affordable solutions to complex control and measurement problems as well.

Based in Tucson, Arizona, Alicat is an intellectual warehouse of engineers and technical support staff educated and tested in a variety of disciplines. These include degrees and field experience in areas such as aerospace, astrophysics, atmospheric sciences, electrical design engineering, mechanical engineering, optical engineering, fuel cell sciences, paint robotics, bio-pharmaceutical instrumentation, semiconductor manufacturing and food packaging and processing.

Alicat understands that there is seldom an “off-the-shelf” solution to a dilemma. That is why we are always ready to customize our core products to fit your needs. The unique design and measuring technologies of Alicat flow and pressure control products allow our instruments to be used in applications where competing devices may not have the flexibility or durability to survive.

You can find Alicat instruments in everything from mining projects to NASA space programs to environmental monitoring and even artificial heart machines.

Halma p.l.c. (www.halma.com) is the parent company of Alicat Scientific, Inc. Halma protects lives and improves quality of life for people worldwide through innovation in market leading products which make its customers safer, more competitive and more profitable.

Halma is a public company listed on the London Stock Exchange and has over 3600 employees in over 40 subsidiaries worldwide.

Our Vision:

“For Alicat to be the recognized leader in flow and pressure measurement by focusing on our core principles of customer support and innovative product design.”

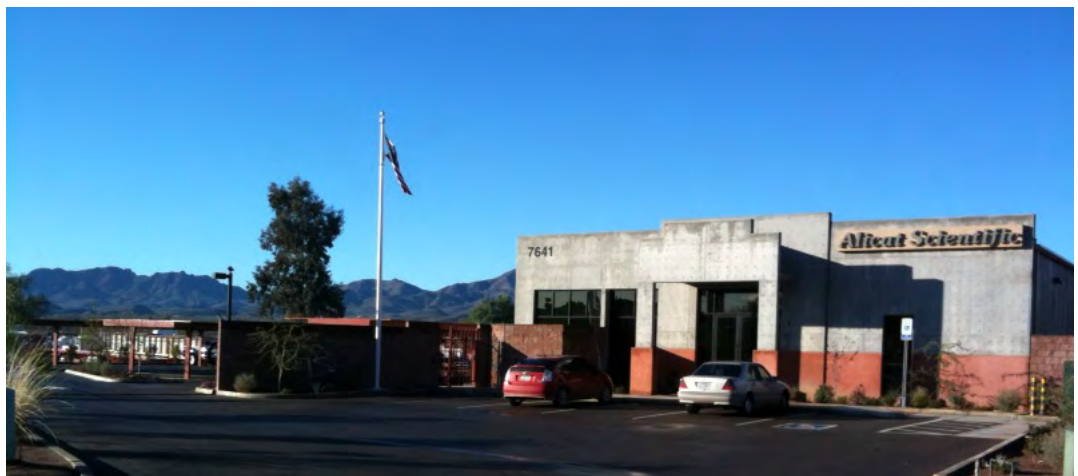

Contents

Alicat Technology	6
Advantages & Benefits	7
Thirty Gas Select™ Standard	8
Flow Vision™ SC	9
Flow Vision™ MX	9
Customization	10
Mass Flow Meters	12
Portable Flow Meters and Pressure Gauges	14
Portable Calibration Unit (Mobile Secondary Calibration Standard)	14
Portable GC Mass Flow Test Kit	15
MS and MCS Mass Flow Meters and Controllers for Aggressive Gases	16
Mass Flow Controllers	24
MCV Mass Flow Controllers with Integrated Positive Shut-off Valve	26
Digital Pressure Gauges and Controllers for Gas and Water	36
Meters and Controllers for Water	49
Options, Accessories, Support	
More Communications Options	53
ATEX and CSA Class 1 Division 2	53
TFT LCD Color Display	53
DB15 Connector	53
Remote Display	54
Remote Electronics for High Temperature Applications	54
NeSSI Compatible	54
Welded Fittings	54
Accessories	
BB-9 Multi-Drop Break-out Box	55
Power Supply	55
Fittings, Filters, Adapters	55
Connecting Cables	56
Application Notes	
Sputtering Flow Control	57
External Ion Gauge Vacuum Control System	58
Alicat Controllers in SOFC Applications	59
Fuel Cell Testing	60
Faster Leak Checking	61
In-House Check of Gas Chromatograph Operation	62
Flame and Burner Monitoring	63
TIG (Tungsten Inert Gas) Welding	64
Reliable Air Delivery for Automated Liquid Paint Application	65
Bioreactor Outgassing	66
Product Sparging	67
Fluid Dispensing Using Pressure Control	68
Mixed Gas Re-metering	69
Approximate Shipping Weights	70
Domestic Distributors	71
International Distributors	71

ALICAT TECHNOLOGY

Alicat Laminar Mass Flow devices address many of the drawbacks to classic orifice plate type volumetric flow measurement as a basis for mass flow calculations.

They also address limitations of thermal flow technology in regards to hot-wire drift, micro-flow calculations and response time.

Alicat mass flow meters and mass flow controllers operate on the same principles as many larger, laminar transfer standards, but in a small, easily integrated package.

Theory of Operation: Volumetric Flow Base

The operating principle of the volumetric unit is based on the physics of the Poiseuille Equation (Equation 1). The Poiseuille Equation quantifies the relationship between pressure drop and flow.

In its simplified form (Equation 2), K is a constant factor determined by the geometry of the restriction.

Equation 1: $Q = (P_1 - P_2)\pi r^4 / 8\eta L$

Where:

Q = Volumetric Flow Rate

P_1 = Static Pressure at Inlet

P_2 = Static Pressure at Outlet

r = Hydraulic Radius of Restriction

η = (eta) Absolute Viscosity of Fluid

L = Length of Restriction

Equation 2: $Q = K(\Delta P / \eta)$

Where:

K = constant dependent upon the geometry of the LFE.

It shows the linear relationship between volumetric flow rate (Q), differential pressure (ΔP), and absolute viscosity (η).

To use the Poiseuille Equation, an internal restriction is created. This restriction is known as a Laminar Flow Element (LFE), represented by r and L in Equation 1.

The LFE forces the gas molecules to move in parallel paths along the length of the passage, eliminating flow turbulence and creating a state of laminar gas flow beneath the Reynolds threshold of 2000. (The Reynolds number of 2000 is commonly accepted as the theoretical threshold. This number will vary depending on surface characteristics.)

Next the differential pressure drop is measured within the laminar region.

Finally, the viscosity of the gas (η) must be determined as affected by gas temperature.

This procedure is performed internally by the microprocessor.

Theory of Operation: Mass Flow Conversion

Alicat mass flow devices start with the volumetric flow rate calculation as previously described. Additional measurements and calculations are incorporated to determine the actual mass flow rate of the gas.

Ideal gas laws show us that the density of a gas is affected by its temperature, absolute pressure and compressibility.

Using non-ideal gas laws requires a reference to a standard temperature and pressure (STP) condition for "normalizing" the mass flow calculation.

Essentially this is a determination of the density of the gas at sea level and a predetermined temperature as related to the actual flow conditions.

In order to determine the mass flow rate, two correction factors must be applied to volumetric flow rate: temperature effect on density and absolute pressure effect on density (Equation 3).

Equation 3: $M = Q(T_s / T_a)(P_a / P_s)(Z_s / Z_a)$

Where:

M = Mass Flow

Q = Volumetric Flow (From Equation 2)

T_s = Absolute Temperature @ Standard Condition in Kelvin

T_a = Absolute Temperature @ Flow Condition in Kelvin

P_a = Flow Absolute Pressure

P_s = Absolute Pressure @ Standard Condition

Z_a = Compressibility at Measured Conditions

Z_s = Compressibility at Standard Conditions

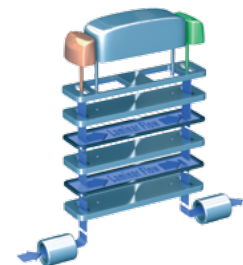

In an Alicat mass flow instrument, a discrete absolute pressure sensor and a temperature sensor are placed in the laminar region of the flow stream.

The sensors send information to the microprocessor which determines mass flow.

A series of calculations is performed and flow rate data is updated an average of 1,200 times/second.

This allows for extremely fast, real time measurements of flow that are sensitive enough to report pulsations in flow, as well as step changes.

ADVANTAGES & BENEFITS

Warm-Up Time Less than one second, ready in an instant!

Speed of Response & Control 10 milliseconds to read! 50-100 milliseconds to control!

Gas Select™

You can use your device with any of 30 precalibrated gases from the gas select menu on the display or via digital communication. You no longer need to purchase a different meter for each gas (page 8).

Dynamic Digital Display w/ Push Button Interface

All standard Alicat instruments include a display with a push button membrane switch. All process parameters that the device measures can be viewed on the main display. A mode button allows you to move from screen to screen to set control data, select gas type or view and reset the optional totalizer. An optional backlit TFT display is also available.

Stand Alone “Smart” Devices

Once an Alicat controller is powered, the control functions can be actuated through the membrane buttons and display screen. No input signal is required. The controller will hold a set-point and control at a given flow rate or pressure until the set-point is changed or power lost. The set-point is maintained even after a power outage and reboot.

Programmable Geometric Running Average

Because the instrument’s response time – 10ms or less in some instances – may be too fast, we provide an averaging function to help smooth the signal output for applications such as data recording and trending.

Field Adjustable PID Loop Tuning

All controllers have a field adjustable PID loop which can be tuned via the push button interface on the display, or via digital communication. You have the ability to adjust the tuning to exactly match your process requirements.

Multiple Analog Outputs

All Alicat instruments have both an analog output and RS-232 input/output. An optional second analog output is available that can be used for any parameter that meter is measuring) Other optional outputs include RS-485, PROFIBUS and DeviceNet..

Tare Function: Automatic, Push Button or Remote

All flow meters with display include a push button tare you can use to zero the meter when no flow is present. On controllers, the tare is automatic when the set-point is at zero for longer than two seconds. A remote tare (ground to tare) is also included for meters in integrated applications.

Mass Flow Controllers can Control Absolute Pressure or Volumetric Flow

Field selectable loop closure allows a mass flow controller to control absolute pressure or volumetric flow rate. This saves in component and design costs, as the mass controller can be used as a pressure controller that also provides information on the actual mass and volumetric flow rates.

Power Requirements

All Alicat meters operate on +7-30 Vdc. No special ± 15 Vdc required. Meters require only 0.04 Amps while controllers need between 0.250 and 0.750 Amps at 12-30 volts depending on flow range.

Turndown

200:1 turndown for all standard gas instruments and 50:1 for liquid instruments.

Customization

Alicat is well known for its ability to modify our core products to fit a customer’s needs. This includes special engineering, units of measure, different body materials, end fittings, special gas mixtures, alarm output drivers and more.

THIRTY GAS SELECT™ STANDARD

All Alicat gas flow meters and controllers come with Gas Select™ and can be used with any of 20 common gases and 10 gas mixtures!

Selectable Gases

Acetylene

Air

Argon

iso-Butane

normal-Butane

Carbon Dioxide

Carbon Monoxide

Ethane

Ethylene

Helium

Hydrogen

Krypton

Methane

Neon

Nitrogen

Nitrous Oxide

Oxygen

Propane

Sulfur Hexafluoride

Xenon

Selectable Gas Mixtures

75% Argon / 25% CO2

90% Argon / 10% CO2

92% Argon / 8% CO2

98% Argon / 2% CO2

75% CO2 / 25% Argon

75% Argon / 25% Helium

75% Helium / 25% Argon

90% Helium / 7.5% Argon / 2.5% CO2

(Praxair - Helistar® A1025)

90% Argon / 8% CO2 / 2% Oxygen

(Praxair - Stargon® CS)

95% Argon / 5% Methane

PgUP	PgDWN	Main
C2H6	Ethane	
H2	Hydrogen	
He	Helium	
>N2	Nitrogen	
N2O	Nitrous Oxide	
Ne	Neon	
UP	DOWN	Gas

**Simply Scroll the Display
and Select a Gas!**

If your application calls for a gas or gas mixture not on this list, please let us know. Alicat Scientific can calibrate to a wide variety of complex gas mixtures involving up to four gas constituents. The percentage of each gas is required at the time of order for the calculation of the mixture's viscosity and temperature curve characteristics. The gas mixture will then be added to the device's gas calibration list. The mix can be selected via RS-232 or local display. Alternately, we can suppress the 30 gas selection and default a device to a specific gas mixture calibration, please consult factory for cost.

FLOW VISIONTM SC

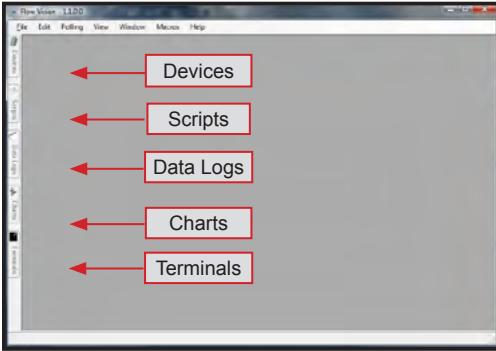

Flow VisionTM SC is an intuitive software interface to help your test cycles run smoother and shorten your engineering time!

Flow VisionTM SC lets you connect to and communicate with multiple Alicat units simultaneously. Now you can view virtual displays, control tabs, charts and data lines from every connected Alicat device on the same screen.

Flow VisionTM SC supports all RS-232 or RS-485 Serial communication functions, including: **gas selection, taring, set-point control, valve tuning and flow averaging.**

Session Saving: Save and reload your configuration data with confidence.

Script Building: Create scripts to adjust a controller's set-point value at variable specified time intervals.

Charting: Chart as many parameters as you want off as many devices as you want, with color coding, zooming, and printing functionality.

Alarms: Create software alarms that will notify you of given parameter conditions.

Data Capture & Logging: Capture and log data to either a .csv file or a .txt file. Improved Data Logging and Data Log File Splitting for easy to manage data.

Flow VisionTM SC supports multiple devices connected to the same RS-232 or RS-485 port.

Simply connect each device to a **BB-9 Multi-Drop Box**, then using device addressability, assign an identifier to each instrument. **The Alicat BB-9 Multi-Drop Box is now available with a USB interface.** See page 55.

Now you can easily monitor and control multiple Alicat instruments from your computer.



FLOW VISIONTM MX

Alicat's New Flow VisionTM MX software gives you an easy way to do GAS BLENDING using Alicat Mass Flow Controllers and your own PC.

Flow VisionTM MX software is a simple way to connect up to six Alicat mass flow controllers and create your own gas mix concentrations.

Using our inexpensive **BB9-USB** and a single USB connection you can:

- **Create** your own gas blends
- **Adjust** flow rates
- **Save** your specific blend formulas.

All the controllers can be powered through the BB9-USB with a single power supply.

Just connect your unique gases to each controller, select the gas type either locally on the controller or through Flow VisionTM MX, manifold the flow outputs and create your gas mix.

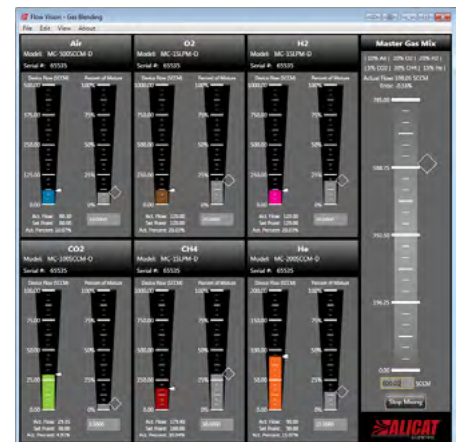

CUSTOMIZATION

There are many ways our units may be tailored to fit your specific application, typically for a low fee. Our engineers are available to assist you with any questions you may have regarding the optimal configuration for your application. Please call us or contact an engineer at info@alicatscientific.com for further information.

Gas Mixtures

Available on M, MC, and MCR units, Alicat Scientific can calibrate to a wide variety of complex gas mixtures involving up to eight gas constituents. The percentage of each gas is required at the time of order for the calculation of the mixture's viscosity vs. temperature curve characteristics. The gas mixture will then be added to the device's gas calibration list. The mix can be selected via RS-232 or local display. Alternately, we can suppress the 30 gas selection and default a device to a specific gas mixture calibration.

6-pin Locking Industrial Connector, DB9, or DB15

A locking 6-pin industrial connector can be added to any device. The industrial connector has a limited number of total output options in comparison to the standard 8-pin DIN connector. We also have DB9 and DB15 connectors to match competitive pin out configurations.

Customized Pressure Drops

Alicat mass flow meters and controllers have one of the lowest pressure drops in the industry, still there are applications where pressure drop across a device is critical. For those applications Alicat can provide a specially designed body with more sensitive pressure sensors and in many instances cut the pressure drop by 80%.

However, as the pressure drop decreases it is possible the accuracy of the device will also degrade. When low-drop device part numbers are provided, revised accuracy specifications are included.

Vacuum Applications

Standard Alicat M Series flow meters will work with mild vacuum applications down to 11.5 PSIA without changes to ordered part. Lower pressures (to 1.5 PSIA) are possible with customization.

Alicat MC and MCR controllers can also be utilized for high vacuum applications. It is strongly encouraged that at time of order you request a downstream valve. There is no charge for this option.

Alternate STPs (Standard Temperature and Pressure)

Alicat M, MC & MCR devices use a default STP of 25°C and 14.696PSIA in flow calibration. We have designed our units so that at no cost you may order an alternate STP. The device STP is stated on the calibration sheet. Other common STPs include 0°C & 14.696PSIA and 20°C & 14.696PSIA.

Bidirectional Flow Readings

Alicat M Series gas meters can be ordered with a full scale calibration in both directions. Display and RS-232 mass flow outputs indicate direction of flow with "+" and "-" signs. Includes NIST traceable calibration in both directions. Note, device accuracy is based on total span; \pm (0.8% of reading + 0.2% of total span positive full scale to negative full scale), e.g. a 2SLPM meter with bidirectional flow @ +1SLPM reading or @ -1SLPM reading has an accuracy specification of ± 0.016 SLPM. 0-5Vdc and 0-10Vdc analog bidirectional outputs available, for example:

5BDM 0-5Vdc bi-directional output of mass flow. Zero flow at 2.5Vdc

10BDM 0-10Vdc bi-directional output of mass flow. Zero flow at 5Vdc

CBDM 4-20mA bi-directional output of mass flow. Zero flow at 12mA

Alternate Units of Measure

All devices are listed in full-scale ranges of cubic centimeters/minute, liters/minute or pounds/square inch. Alternate units of measure are available at no additional cost. Commonly requested alternate units of measure include SCFM, SCFH, mmHG, and inH₂O.

We want your input!

***If you have any suggestions, ideas or concerns regarding any Alicat product —
Please contact us at: feedback@alicatscientific.com.***

Totalizer

Flow meters and controllers can be ordered with the Totalizing option. This option adds an additional mode screen that displays the total flow (normally in the units of the main flow screen) that has passed through the meter or controller since the last time the Totalizer was cleared. The counter range is six digits (leading zeroes suppressed).

At the time of order, you specify the resolution of the count. For instance, if a resolution of 1/100ths of a liter is specified for a meter, which is totalizing in liters, the maximum count would be 9999.99 liters. If the same unit were specified with a 1 liter resolution, the maximum count would be 999999 liters.

You will also choose what the Totalizer is to do when the maximum count is reached:

No Rollover – When the counter reaches the maximum count – it stops counting until the counter is cleared.

Rollover – When the counter reaches the maximum count – it automatically rolls over to zero and continues counting until the counter is cleared.

Rollover with Notification – When the counter reaches the maximum count – it automatically rolls over to zero, displays rollover error (OVR) and continues counting until the counter is cleared.

The display shows the elapsed time since the last reset in 0.1 hour increments. The maximum measurable elapsed time is 6553.5 hours (about nine months). The hours count resets when the “Clear” button is pushed, an RS-232 clear is executed, or on loss of power (a battery back-up can prevent Totalizer clear when power is lost). The counter can be reset to zero at any time by pushing the “RESET” button or via an RS-232 serial command.

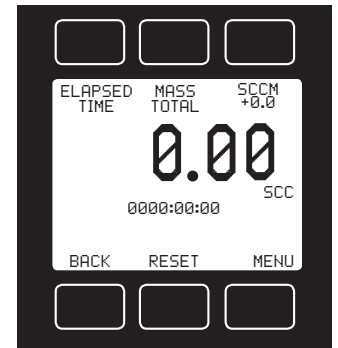

Mass Device Totalizer Display

Pulse Output (PUL: Flow):

Available on all flow devices, the pulse output option is a simplified totalizer. It is available on pin 2 of the 8-pin mini din connector. Units with the pulse output function do not have the static 5.12Vdc output, the option for a secondary analog output or alarm. The parameters for the pulse output are factory set and must be requested at time of order. This option will create a state change on pin 2 from 0Vdc to 5Vdc (or 5Vdc to 0Vdc on alternate periods) each time one half of the total amount of predefined flow passes through the unit. For example:

M-10SLPM-D /5M, PUL:0.1SL

Every time a total flow of 0.1 standard liter passes through the unit, Pin 2 will go from 0 to 5Vdc after 0.05 standard liter passes through and from 5Vdc to 0 after the next 0.05 standard liter passes through.

Alarms

Alicat M, L or P Series meters and gauges can be ordered with a simple alarm. You can program in the field the alarm set-point via the local display, RS-232 or analog input. There are two types of alarms available. Both types operate on pin 2 of the 8-pin mini-din connector (detailed diagram page 10). Units with the alarm function do not have the static 5.12Vdc output, the option for a secondary analog output or the pulse ability.

ALH: This alarm format, which is programmed by the factory, will cause pin 2 to go from a 0Vdc output directly to a 5Vdc output when the alarm set-point is exceed. For example, a 0-20SLPM mass meter (M) is programmed by the user with an alarm condition of 13.75SLPM. When the flow exceeds 13.75SLPM, pin 2 will change state to a 5Vdc output. For a pressure gauge (P) series, the alarm state change will occur when the pressure exceeds the set-point .

ALL: This alarm format is similar to the ALH option, except the state change to 5Vdc occurs when the process parameter (flow or pressure) is under the set-point .

Please consult the factory for additional customization options, including:

- Customized process connections
- Alternate materials of construction (e.g. aluminum bodies to reduce weight)
- Complete private label package (labels, software, manuals, etc.)

MASS FLOW METERS

Alicat Scientific's M Series Mass Flow Meters Ready in an Instant to Respond in 10 milliseconds or Less!

The innovative features built into every Alicat mass flow meter are there to save you time and money. Unlike traditional mass flow meters, Alicat mass flow meters utilize laminar flow and differential pressure technology. The result is an extremely fast, accurate meter with no warm-up time and unparalleled versatility.



M 250SLPM

Multi-gas Selectivity

All Alicat flow meters come with Gas Select™. They are calibrated and ready for use with 20 gases and 10 gas blends. You select the gas via the display or through the RS-232 or RS-485 interface. See page 8 for gas list.

In addition, Alicat can calibrate your meter for gas mixtures specific to your applications.

High Accuracy and 200:1 Turndown

Alicat mass flow meters have a standard accuracy of \pm (0.8% of reading +0.2% of full scale).

We also offer a high accuracy calibration of \pm (0.4% of reading + 0.2% of full scale) for flow meters ranging from 5SCCM to 500SLPM with a 200:1 turndown.

This makes it possible to use a single Alicat meter to measure an operating flow range that would normally require two typical mass flow meters — and still maintain your required accuracy!

Multiple Parameter Measurement & Optional Alarm Set-Point

All Alicat mass flow meters measure *mass flow*, *volumetric flow*, *absolute pressure* and *temperature*!

This unique feature will save money by eliminating extra transmitters and their cost of installation. The additional process information is invaluable for troubleshooting or to alert you of upsets before they become catastrophic. (Monitoring of critical parameters can be further simplified with an optional alarm set-point for temperature, pressure or flow.)

No Warm-Up Time!

Thermal type mass flow meters need anywhere from 10 to 30 minutes of warm-up time before they become stable. The Alicat pressure based technology needs less than one second to reach stability. A time delay of 30 minutes could be critical if your meter is being used for process tuning, monitoring or control.

With an Alicat mass flow meter, in less than a second after power up, you are ready to begin accurate measurement and control of your process.



M 5SLPM

M Series: Meters in any flow range from 0 to 0.5SCCM FS through 0 to 3000SLPM FS

Are you aware that “Standard Conditions” aren’t always standard?

Have you ever tested two different meters on the same flow rate only to get two different readings? That’s probably because the meters were calibrated using different standard conditions. This can be quite a problem if you need both meters to read the same.

With an Alicat meter, you can simply change the standard condition parameters via RS-232 or RS-485 communication and you’re up and running.

No need to send it back to the factory for recalibration — saving both time and money!

Low Power Operation

If you’re concerned with power consumption, Alicat’s mass flow meters have the lowest power requirements in the industry.

Any M Series meter can run on 7 to 30 Vdc and consumes only 0.04 Amps!

You could even use a small solar panel for power in a remote operation.

No Straight Runs Necessary

If your space is limited, Alicat combines a small footprint with the ability to connect from an elbow directly into and out of the flow body.

Because our unique design creates laminar flow within the flow body —

No Straight Runs Of Pipe Are Required.



M 2000SLPM

Digital and Analog Communication Included on All Alicat Products

All Alicat instruments come with analog and digital communication. No special software is needed to communicate digitally with your Alicat mass flow meter.

Alicat provides free LabView® drivers or you can connect directly through HyperTerminal® which is standard with Windows XP® operating systems. Alicat can also provide the Flow Vision™ SC software program — designed specifically for Alicat flow and pressure products (page 9).

You can also download free COM Port Troubleshooter and Serial Terminal applications from the Software page of our website.

NEW Alicat MQ Mass Flow Meters For High Pressure Applications

The flow rate is dependent on the pressure in that lower pressures will yield lower flow rates. The Q series devices are highly specialized and should only be ordered after consulting Alicat.

MQ flow meters are calibrated for operation at high pressure. Optimal performance is achieved at higher operating pressures.

Minimum Operating Pressure – 30PSIA

Maximum Operating Pressure – 320PSIA

Lifetime Warranty

Alicat not only brings you excellent products, we back them with a lifetime warranty, engineering support, quick delivery and low cost recalibration.

Our new order lead time is typically two weeks. Recalibrations are normally on their way back to you within three business days!

Now Available:

ATEX / CSA Class 1 Division 2 hazardous environment for Europe, Canada and the U.S.

PROFIBUS DP-V1

DeviceNet

RS-485 Serial Output

PORTABLE FLOW METERS AND PRESSURE GAUGES

Laboratories, industrial plants, process facilities and field technicians have all gained substantial advantages from Alicat portable flow meters and pressure gauges.

Instead of spending your time finding (or hard wiring) a power source, you can utilize our portable meter with gas selection and multiple parameter measurement features to:

Verify proper operation of equipment, *including* other manufacturer's flow meters and flow controllers

Maintain proper equipment settings as components within the system wear down

Search for leaks in the system utilizing the pressure reading or the flow reading

Install equipment and perform initial tuning and adjustments in the field

Perform periodic system checks for quality control and verification

A common 9Vdc battery powers one of our portable M Series meters for 8 - 10 hours!

This affordable device displays mass flow & volumetric flow along with process temperature and pressure for 30 field selectable gases.

The unit can also be powered with an optional AC/DC plug-in adaptor.

Many of our customization features are compatible with our Portable Meters, including:

- ▶ Alternate STPs to simplify comparisons to other flow devices
- ▶ High accuracy calibration
- ▶ Gas mixture calibrations or special gases
- ▶ Integrated Totalizer for tests that require long term averaging



MB 500SCCM-TFT

PORTABLE CALIBRATION UNIT MOBILE SECONDARY CALIBRATION STANDARD

Alicat's **Portable Calibration Unit (PCU)** is a self contained, portable secondary calibration standard that is easy to transport and use.

Don't waste engineering time or lose revenue for equipment downtime while verifying calibration on in-service flow equipment.

The Alicat PCU is built into an industrial Pelican® case and can be taken anywhere you need it!

Unlike typical secondary standards, **the PCU is fully self-contained and requires no additional support equipment or line power.**

It is as simple as having your technician arrive on site, plug the unit into the system and take readings.

The PCU also has **on-board digital output** enabling it to send flow data to your laptop or computer system.

The PCU is comprised of three Alicat M series flow meters powered by two common 9Vdc batteries or a 9-20Vdc wall outlet adaptor.

Like Alicat's standard line of flow devices the PCU has no moving parts to service or fail.

You specify the ranges of the flow meters when ordering the PCU.



Case: 16' L x 13' W x 7' H
Weight: 12 - 20 lb depending on configuration

Alicat's New Portable GC Mass Flow Test Kit



Case: 10.5" L x 9.5" W x 5" H

Alicat takes its proven MB Series Meter for portable mass flow, volumetric flow and pressure verification to the next level by packaging it with all the desired accessories in a convenient sturdy carrying case.

The **Mass Flow Test Kit** allows you to move from system to system without the concern for a power source or special fitting requirements.

Each Kit Includes: one MB Mass Flow Meter calibrated to a specified range (usually 500 mL/min); universal AC/DC power adapter; spare 9Vdc battery; and the appropriate fittings and tubing.

The rugged MB Series Mass Flow Meter uses Alicat's patented laminar flow technology and is backed by our famous **limited lifetime warranty**.

With its unmatched turndown ratio of 200:1, a 500 SCCM meter can accurately read flows down to 2.5 SCCM.

Each MB Meter Includes:

- ▶ NIST Traceable Eight Point Calibration Certificate
- ▶ Display of Mass Flow, Volumetric Flow, Absolute Pressure and Temperature
- ▶ LCD Display (Color TFT Optional)
- ▶ 30 Pre-Programmed Gas Selections
- ▶ RS-232 Digital output (USB converter optional) and 0-5 Vdc output
- ▶ Standard 9Vdc battery
- ▶ Flow Totalization

Meter Specifications:

- ▶ Accuracy: +/-0.8% reading +/-0.2% Full Scale (available high accuracy option: +/-0.4% reading +/-0.2% FS)
- ▶ 10 millisecond response
- ▶ Turndown of 200:1
- ▶ Warm up time < 1 second

Typical Applications Include:

- ▶ Verification of Gas Chromatograph carrier gas and capillary flow rates
- ▶ Verification of Volumetric flow and Mass flow on inputs and vents
- ▶ Verification of the pressure on the inlet and vent of the Gas Chromatograph
- ▶ System leak checking using pressure or flow measurement

Industrial Carrying Case

The case is gasket sealed, providing an air and watertight closure. A barometric relief valve prevents damage to the case or its contents when the air pressure in the environment changes.

Options Include:

USB converter; Color TFT display; RS-485 output; and Alicat's unique Flow VisionTM SC software (with communication cable) for logging and storing data.

Available in Full Scale Ranges Down to 0.5 SCCM

Also Available:

Alicat's Portable Liquid Meter Kit for High Performance Liquid Chromatography Flow Calibration. Call for details.

NEW MS and MCS SERIES for AGGRESSIVE GASES

Alicat is proud to introduce the MS and MCS Series of mass flow and control instruments for corrosive gases.

Our MS meters and MCS controllers feature all 316L Stainless Steel construction along with selectable elastomeric materials depending on the corrosive gas type. The MCS Series controllers add a stainless steel control valve.

MS and MCS units have all the same standard features and functionality that every Alicat mass flow product includes, such as 10 millisecond to read or measure and 100 millisecond to control response times, 30 gas select, digital display, high accuracy and lifetime warranty.



MS gas compatibility list :

NO to 100%
NF3 to 100%
NH3 to 100%
Cl2 to 100%
H2S to 100%
SO2 to 100%
Dimethyl Ether to 100%
Propylene to 100%
Refrigerant gases to 100%
NO2 to 0.5% in an inert carrier

MCS gas compatibility list:

NO to 100%
NF3 to 100%
NH3 to 100%
H2S to 100% (22° C and under)
Dimethyl Ether to 100%
Propylene to 100%
Refrigerant gases to 100%
NO2 to 0.5% in an inert carrier
Other gases to 1000 ppm in an inert carrier

Specification	MS Mass Meter	MCS Mass Controller	Description
Accuracy	± (0.8% of Reading + 0.2% of Full Scale)		At calibration conditions after tare
High Accuracy Option	± (0.4% of Reading + 0.2% of Full Scale)		At calibration conditions after tare
Repeatability	± 0.2%		Full Scale
Operating Range	1% to 100% Full Scale		Measure and Control
Typical Response Time	10	100	Milliseconds (Adjustable)
Standard Conditions (STP)	25°C & 14.696PSIA		Mass Reference Conditions
Operating Temperature	-10 to +50		°Celsius
Zero Shift	0.02%		Full Scale / °Celsius / Atm
Span Shift	0.02%		Full Scale / °Celsius / Atm
Humidity Range	0 to 100%		Non-Condensing
Measurable Flow rate	128%		Full Scale
Controllable Flow Rate		102.4%	Full Scale
Maximum Pressure	145		PSIG
Input /Output Signal Digital	Mass, Volumetric Flow, Pressure & Temperature		RS-232 or RS-485 Serial, PROFIBUS, DeviceNet ¹
Input / Output Signal Analog	Mass Flow		0-5Vdc
Optional Input / Output Signal Secondary Analog	Mass, Volumetric Flow, Pressure & Temperature		0-5 Vdc or 0-10Vd or 4-20mA
Electrical Connections	8 Pin Mini-DIN or DB-15		
Supply Voltage: MS Meters	7 to 30 Vdc (15-30Vdc for 4-20mA outputs)		
Supply Voltage: MCS Controllers	12 to 30 Vdc (15-30Vdc for 4-20mA outputs)		
Supply Current: MS Meters	0.04 Amp (+ output current on 4-20mA)		
Supply Current: MCS Controllers	0.250Amp (at 12 Vdc, declining with increased supply voltage)		
Mounting Attitude Sensitivity	None		
Warm-up Time	< 1		Second
Wetted Materials ²	316LSS, FFKM (Kalrez) standard; Viton, EPDM, as needed for some gases. MCS controllers add: 303SS, 430 FRSS.		

1. If selecting PROFIBUS or DeviceNet no analog signal is available. PROFIBUS and DeviceNet units do not have the display. See PROFIBUS and DeviceNet specifications for supply voltages and currents.

2. Wetted Materials may differ for some corrosive gases. Please contact Alicat for exact materials and available options.

Technical Data for Micro-Flow and Ultra-Low Flow M Mass Flow Meters

0 to 0.5SCCM Full Scale through 0 to 50SCCM Full Scale

The following specifications are for the standard configuration of the product. There are many options available.

Specification	Mass Meter	Description
Accuracy	± (0.8% of Reading + 0.2% of Full Scale)	At calibration conditions after tare
High Accuracy Option	± (0.4% of Reading + 0.2% of Full Scale)	At calibration conditions after tare
Accuracy: Bi-directional Meters Only	± (0.8% of reading + 0.2% of total span positive full scale to negative full scale)	At calibration conditions after tare
Repeatability	± 0.2%	Full Scale
Operating Range	1/2% to 100%	Full Scale
Turndown Ratio	200:1	
Typical Response Time	10	Milliseconds (Adjustable)
Standard Conditions (STP)	25°C & 14.696PSIA	Mass Reference Conditions
Operating Temperature	-10 to +50	°Celsius
Zero Shift	0.02%	Full Scale / °Celsius / Atm
Span Shift	0.02%	Full Scale / °Celsius / Atm
Humidity Range	0 to 100%	Non-Condensing
Measurable Flow Rate	128%	Full Scale
Maximum Pressure	145	PSIG
Output Signal Digital	Mass Flow, Volume Flow, Pressure & Temperature	RS-232 Serial or RS-485 Serial or PROFIBUS or DeviceNet ¹
Output Signal Analog	Mass Flow	0-5Vdc
Optional Output Signal Secondary Analog	Mass Flow, Volumetric Flow Pressure or Temperature	0-5 Vdc or 0-10Vdc or 4-20mA
Electrical Connections	8 Pin Mini-DIN or DB-15	
Supply Voltage	7 to 30 Vdc (15-30Vdc for 4-20mA outputs)	
Supply Current	0.040 Amp (+ output current on 4-20mA)	
Mounting Attitude Sensitivity	0%	Tare after installation
Warm-up Time	< 1	Second
Wetted Materials ²	303 & 302 Stainless Steel, Viton®, Silicone RTV (Rubber), Glass Reinforced Nylon, Aluminum.	

1. If selecting PROFIBUS or DeviceNet no analog signal is available. PROFIBUS / DeviceNet units do not have the display. See PROFIBUS or DeviceNet specifications for PROFIBUS or DeviceNet supply voltages and currents.

2. If your application demands a different material, please contact Alicat for available options.

Mechanical Specifications

Full Scale Flow Mass Meter	Mechanical Dimensions	Process Connections ¹	Pressure Drop ² (PSID)
0.5SCCM to 1SCCM	3.9"H x 2.4"W x 1.1"D	M-5 (10-32) Female Thread*	1.0
2SCCM to 50SCCM			1.0

Units ≤50SCCM F.S. are shipped with M-5 (10-32) Male Buna-N O-ring face seal to 1/8" Female NPT fittings.

These adaptor fittings were selected for customer convenience in process connection. It should be noted that the 1/8" Female NPT introduces additional dead volume. To minimize dead volume, please see [Accessories](#) for the 10-32 Male to 1/8"OD compression fitting.

- Compatible with Beswick®, Swagelok® tube, Parker®, face seal, push connect and compression adapter fittings.
- Venting to atmosphere. Lower Pressure Drops Available, please contact Alicat.

0.5SCCM to 50SCCM approximate shipping weight: 0.8lb

Technical Data for Low Flow M Mass Flow Meters

0 to 100 SCCM Full Scale through 0 to 20 SLPM Full Scale

The following specifications are for the standard configuration of the product. There are many options available.

Specification	Mass Meter	Description
Accuracy	± (0.8% of Reading + 0.2% of Full Scale)	At calibration conditions after tare
High Accuracy Option	± (0.4% of Reading + 0.2% of Full Scale)	At calibration conditions after tare
Accuracy: Bi-directional Meters Only	± (0.8% of reading + 0.2% of total span positive full scale to negative full scale)	At calibration conditions after tare
Repeatability	± 0.2%	Full Scale
Operating Range	1/2% to 100%	Full Scale
Turndown Ratio	200 : 1	
Typical Response Time	10	Milliseconds (Adjustable)
Standard Conditions (STP)	25°C & 14.696PSIA	Mass Reference Conditions
Operating Temperature	-10 to +50	°Celsius
Zero Shift	0.02%	Full Scale / °Celsius / Atm
Span Shift	0.02%	Full Scale / °Celsius / Atm
Humidity Range	0 to 100%	Non-Condensing
Measurable Flow Rate	128%	Full Scale
Maximum Pressure	145	PSIG
Output Signal Digital	Mass, Volume, Pressure & Temperature	RS-232 Serial or RS-485 Serial or PROFIBUS or DeviceNet ¹
Output Signal Analog	Mass Flow	0-5Vdc
Optional Output Signal Secondary Analog	Mass, Volumetric Pressure or Temperature	0-5 Vdc or 0-10Vdc or 4-20mA
Electrical Connections	8 Pin Mini-DIN or DB-15	
Supply Voltage	7 to 30 Vdc (15-30Vdc for 4-20mA outputs)	
Supply Current	0.040 Amp (+ output current on 4-20mA)	
Mounting Attitude Sensitivity	0%	Tare after installation
Warm-up Time	< 1	Second
Wetted Materials ²	303 & 302 Stainless Steel, Viton®, Silicone RTV (Rubber), Glass Reinforced Nylon, Aluminum.	

1. If selecting PROFIBUS or DeviceNet no analog signal is available. PROFIBUS / DeviceNet units do not have the display. See PROFIBUS or DeviceNet specifications for PROFIBUS or DeviceNet supply voltages and currents.

2. If your application demands a different material, please contact Alicat for available options.

Mechanical Specifications

Full Scale Flow Mass Meter	Mechanical Dimensions	Process Connections ¹	Pressure Drop ² (PSID)
100SCCM to 20SLPM	4.1"H x 2.4"W x 1.1"D	1/8" NPT Female	1.0

1. Compatible with Beswick®, Swagelok® tube, Parker®, face seal, push connect and compression adapter fittings.

2. Venting to atmosphere. Lower Pressure Drops Available, please contact Alicat.

100SCCM to 20SLPM approximate shipping weight: 1.0lb

Technical Data for Moderate Flow M Mass Flow Meters

0 to 50 SLPM Full Scale through 0 to 250 SLPM Full Scale

The following specifications are for the standard configuration of the product. There are many options available.

Specification	Mass Meter	Description
Accuracy	± (0.8% of Reading + 0.2% of Full Scale)	At calibration conditions after tare
High Accuracy Option	± (0.4% of Reading + 0.2% of Full Scale)	At calibration conditions after tare
Accuracy: Bi-directional Meters Only	± (0.8% of reading + 0.2% of total span positive full scale to negative full scale)	At calibration conditions after tare
Repeatability	± 0.2%	Full Scale
Operating Range	1/2% to 100%	Full Scale
Turndown Ratio	200 : 1	
Typical Response Time	10	Milliseconds (Adjustable)
Standard Conditions (STP)	25°C & 14.696PSIA	Mass Reference Conditions
Operating Temperature	-10 to +50	°Celsius
Zero Shift	0.02%	Full Scale / °Celsius / Atm
Span Shift	0.02%	Full Scale / °Celsius / Atm
Humidity Range	0 to 100%	Non-Condensing
Measurable Flow Rate	128%	Full Scale
Maximum Pressure	145	PSIG
Output Signal Digital	Mass Flow, Volumetric Flow, Pressure & Temperature	RS-232 Serial or RS-485 Serial or PROFIBUS or DeviceNet ¹
Output Signal Analog	Mass Flow	0-5Vdc
Optional Output Signal Secondary Analog	Mass Flow, Volumetric Pressure or Temperature	0-5 Vdc or 0-10Vdc or 4-20mA
Electrical Connections	8 Pin	Mini-DIN
Supply Voltage	7 to 30 Vdc (15-30Vdc for 4-20mA outputs)	
Supply Current	0.040 Amp (+ output current on 4-20mA)	
Mounting Attitude Sensitivity	0%	Tare after installation
Warm-up Time	< 1	Second
Wetted Materials ²	303 & 302 Stainless Steel, Viton®, Silicone RTV (Rubber), Glass Reinforced Nylon, Aluminum.	

1. If selecting PROFIBUS or DeviceNet no analog signal is available. PROFIBUS / DeviceNet units do not have the display. See PROFIBUS or DeviceNet specifications for PROFIBUS or DeviceNet supply voltages and currents.
2. If your application demands a different material, please contact Alicat for available options.

Mechanical Specifications

Full Scale Flow Mass Meter	Mechanical Dimensions	Process Connections ¹	Pressure Drop ² (PSID)
50SLPM	4.4"H x 4.0"W x 1.6"D	1/4" NPT Female	2.0
100SLPM			2.5
250SLPM	5.0"H x 4.0"W x 1.6"D	1/2" NPT Female	4.0

1. Compatible with Beswick®, Swagelok® tube, Parker®, face seal, push connect and compression adapter fittings.
2. Venting to atmosphere. Lower Pressure Drops Available, please contact Alicat.

50SLPM approximate shipping weight: 2.2 lb.
100SLPM approximate shipping weight: 2.4 lb.
250SLPM approximate shipping weight: 3.2 lb.

Technical Data for High Flow M Mass Flow Meters

0 to 500 SLPM Full Scale through 0 to 3000 SLPM Full Scale

The following specifications are for the standard configuration of the product. There are many options available.

Specification	Mass Meter	Description
Accuracy	± (0.8% of Reading + 0.2% of Full Scale)	At calibration conditions after tare
High Accuracy Option ¹	± (0.4% of Reading + 0.2% of Full Scale)	At calibration conditions after tare
Accuracy: Bi-directional Meters Only	± (0.8% of reading + 0.2% of total span positive full scale to negative full scale)	At calibration conditions after tare
Repeatability	± 0.2%	Full Scale
Operating Range	1/2% to 100%	Full Scale
Turndown Ratio	200 : 1	
Typical Response Time	10	Milliseconds (Adjustable)
Standard Conditions (STP)	25°C & 14.696PSIA	Mass Reference Conditions
Operating Temperature	-10 to +50	°Celsius
Zero Shift	0.02%	Full Scale / °Celsius / Atm
Span Shift	0.02%	Full Scale / °Celsius / Atm
Humidity Range	0 to 100%	Non-Condensing
Measurable Flow Rate	128%	Full Scale
Maximum Pressure	145	PSIG
Output Signal Digital	Mass Flow, Volumetric Flow, Pressure & Temperature	RS-232 Serial or RS-485 Serial or PROFIBUS or DeviceNet ¹
Output Signal Analog	Mass Flow	0-5Vdc
Optional Output Signal Secondary Analog	Mass Flow, Volumetric Flow Pressure or Temperature	0-5 Vdc or 0-10Vdc or 4-20mA
Electrical Connections	8 Pin Mini-DIN or DB-15	
Supply Voltage	7 to 30 Vdc (15-30Vdc for 4-20mA outputs)	
Supply Current	0.040 Amp (+ output current on 4-20mA)	
Mounting Attitude Sensitivity	0%	Tare after installation
Warm-up Time	< 1	Second
Wetted Materials ³	303 & 302 Stainless Steel, Viton®, Silicone RTV (Rubber), Glass Reinforced Nylon, Aluminum.	

1. High Accuracy option not available for units ranged over 500SLPM.
2. If selecting PROFIBUS or DeviceNet no analog signal is available. PROFIBUS / DeviceNet units do not have the display. See PROFIBUS or DeviceNet specifications for PROFIBUS or DeviceNet supply voltages and currents.
3. If your application demands a different material, please contact Alicat for available options.

Mechanical Specifications

Full Scale Flow Mass Meter	Mechanical Dimensions	Process Connections ¹	Pressure Drop ² (PSID)
500SLPM	5.0"H x 4.0"W x 1.6"D	3/4" NPT Female ³	5.5
1000SLPM			6.0
1500SLPM			9.0
2000SLPM	5.3"H x 5.2"W x 2.9"D	1-1/4" NPT Female	5.0
3000SLPM	5.3"H x 5.2"W x 2.9"D		7.1

1. Compatible with Beswick®, Swagelok® tube, Parker®, face seal, push connect and compression adapter fittings.
2. Venting to atmosphere. Lower Pressure Drops Available, please contact Alicat.
3. A 1.25" NPT Female optional process fitting is available for 2000SLPM meters

500SLPM to 1500SLPM approximate shipping weight: 3.5lb
2000SLPM to 3000SLPM approximate shipping weight: 4.5lb

M Series Meters Dimensional Drawings

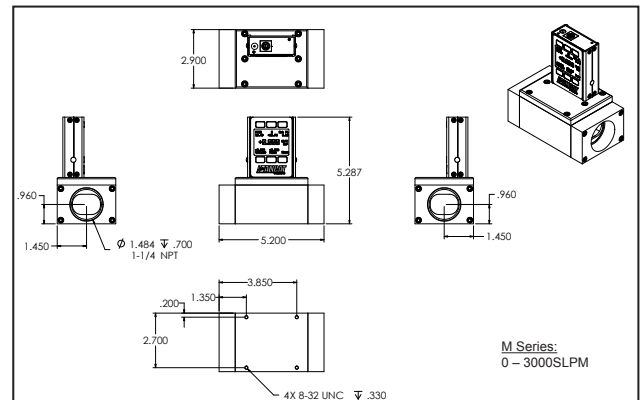
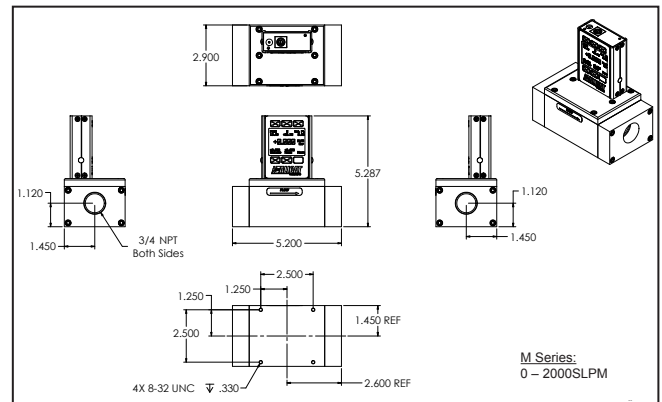
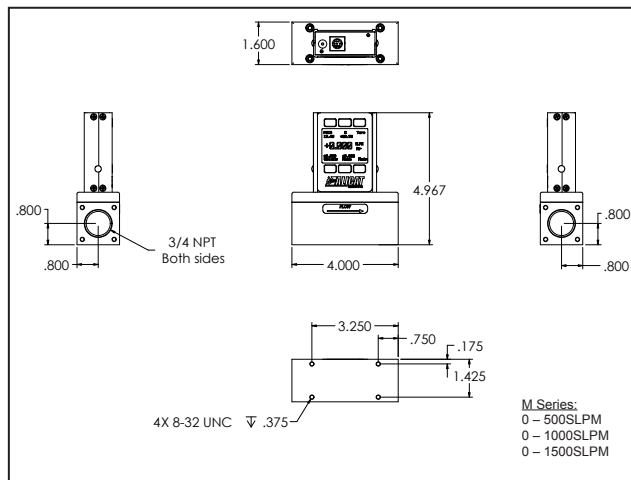
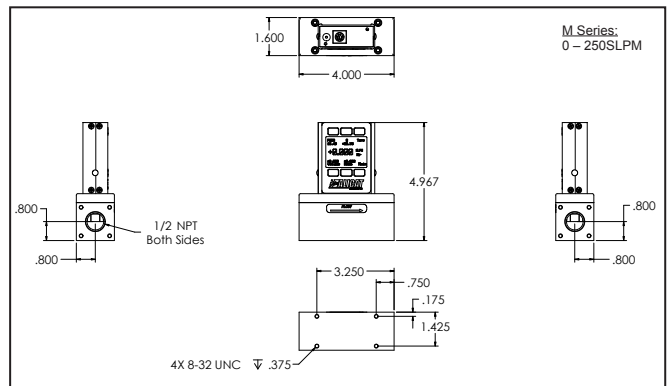
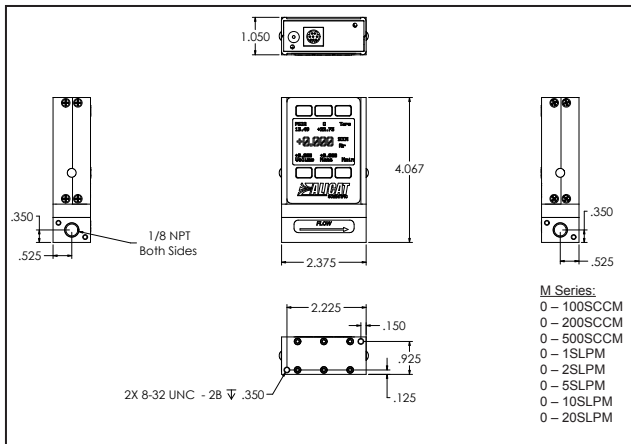
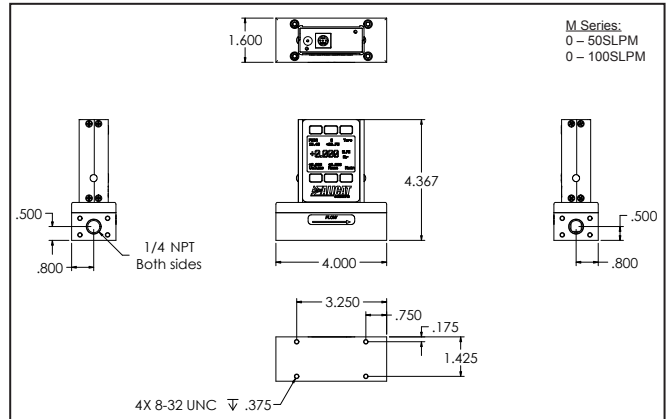
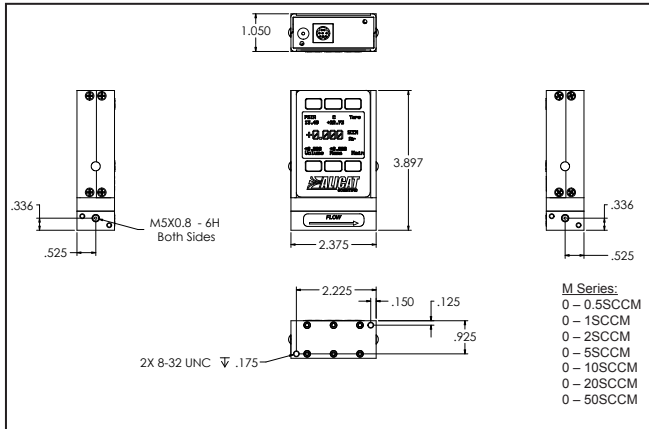

Technical Data for MS Series Mass Flow Meters

Alicat MS instruments are built for use with aggressive gases. For the most part, these instruments maintain the specifications of equivalently ranged M Series devices.

In addition to Alicat's standard 30 gas select programming, MS meters are configured to operate with the following aggressive gases.

MS Meter Gas Compatibility List :

NO	Nitric Oxide to 100%
NF3	Nitrogen Trifluoride to 100%
NH3	Ammonia to 100%
Cl2	Chlorine to 100%
H2S	Hydrogen Sulfide to 100%
SO2	Sulfur Dioxide to 100%
Dimethyl Ether to 100%	
Propylene to 100%	



In addition, the following gases are available upon request:

NO2	Nitrogen Dioxide to 0.5% in an inert carrier
Refrigerant gases to 100%	

If your application requires another gas or gas mixture, please contact Alicat. We will do our best to accommodate your request.

Please refer to the Technical Data for the equivalently ranged M Series instrument for all operating specifications except:

Operating Range	1% to 100%	Full Scale
Turndown Ratio	100 : 1	
Wetted Materials	316LSS, FFKM (Kalrez) standard; Viton, EPDM, as needed for some gases.	

The dimensions of MS instruments may vary from their standard M Series counterparts. Dimensional drawings for MS instruments are shown on page 23

We want your input!

***If you have any suggestions, ideas or concerns regarding any Alicat product —
Please contact us at: feedback@alicatescientific.com.***

MS Series Meters Dimensional Drawings

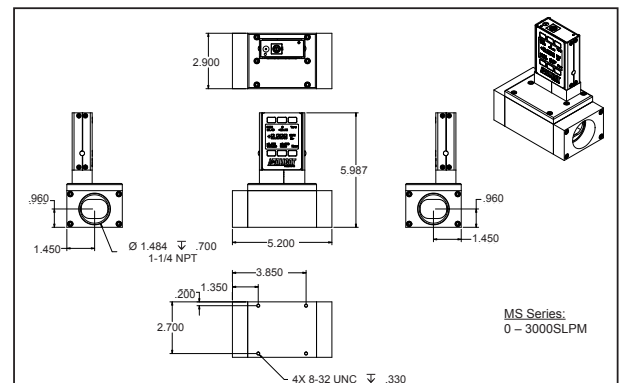
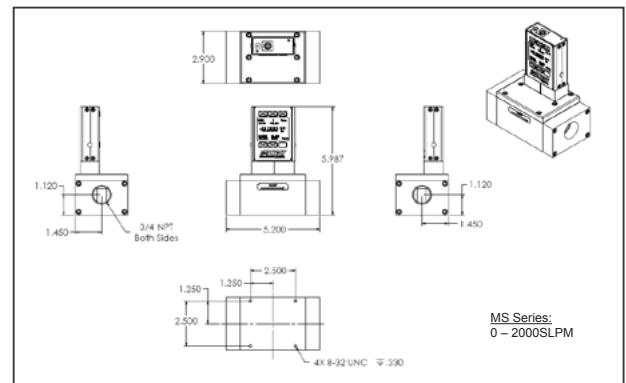
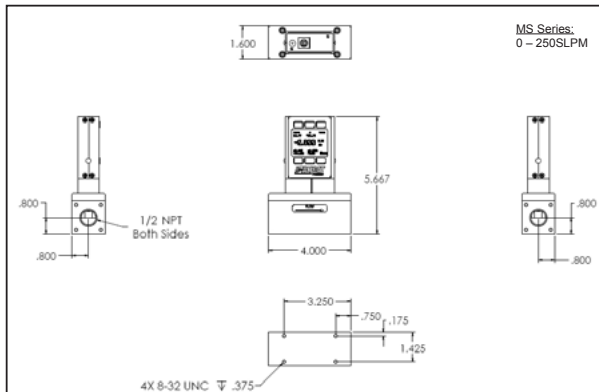
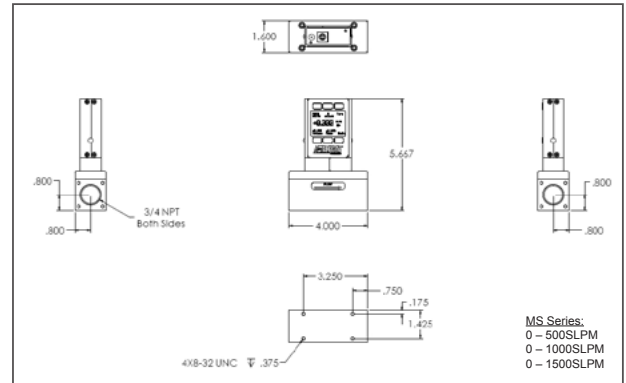
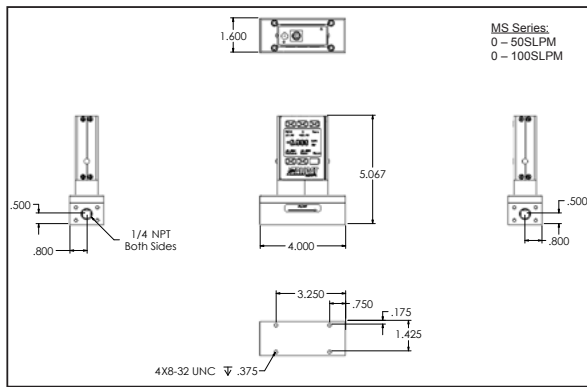
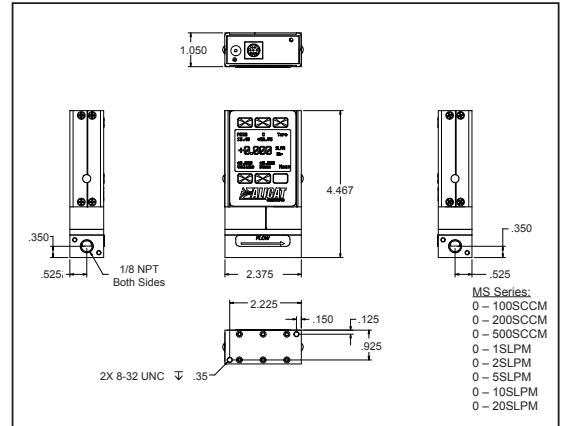
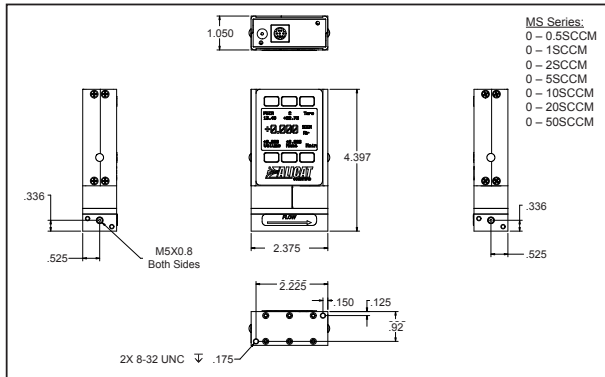

MASS FLOW CONTROLLERS

Process Control Faster than the Process!

Alicat Scientific's MC and MCR Series Mass Flow Controllers Deliver Improved Quality Control and Reduced Process Costs.

Fast!

Alicat's mass flow controllers incorporate an extremely fast responding true proportional valve and PID loop control – resulting in unsurpassed flow control for even the smallest flow rate and low pressure processes.

Control response time ranges from 30 to 100ms with very little overshoot, depending on the size of controller and tuning.

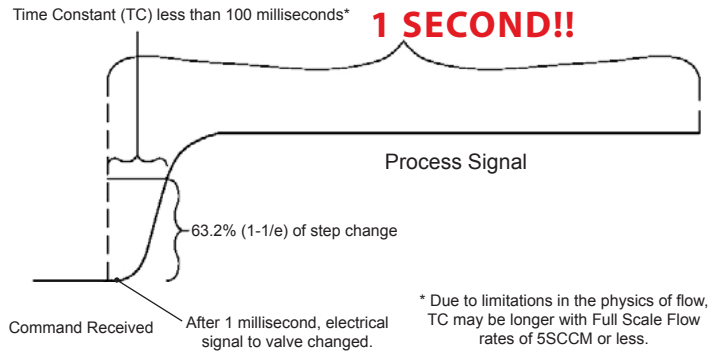

MC 10SLPM

Field Adjustable PID

Although the instruments come well-tuned from the factory, you can optimize your Alicat mass flow controller's performance in the field by adjusting the P or D via the front panel display or through RS-232.

Alicat's larger mass flow controllers (MCR Series) use unique low pressure drop valves to control flow or pressure. This can be critical in gas blending or other processes where precise gas volumes are essential.

Multi-gas Selectivity

All Alicat flow controllers come with Gas Select[™]. They are calibrated and ready for use with 20 gases and 10 gas blends. You select the gas via the display or through the RS-232 interface.

In addition, Alicat can calibrate your controller for gas mixtures specific to your applications. See page 6 for gas list.



MC 20SLPM

No Warm-Up Time!

Thermal type mass flow controllers need anywhere from 10 to 30 minutes of warm-up time before they become stable.

Alicat's pressure based technology needs less than one second to reach stability.

A time delay of 30 minutes could be critical when your meter is being used for process tuning, monitoring or control. With an Alicat mass flow controller, in less than a second after power up you can begin accurate measurement and control of your process.

Multiple Parameter Measurement

All Alicat mass flow controllers measure *mass flow*, *volumetric flow*, *absolute pressure* and *temperature!*

This unique feature saves money by eliminating extra transmitters and their cost of installation.

The additional process information is invaluable for troubleshooting or to alert you of upsets before they become catastrophic.

High Accuracy and 200:1 Turndown

Alicat mass flow controllers have a standard accuracy of \pm (0.8% of reading + 0.2% of full scale).

We also offer a high accuracy calibration of \pm (0.4% of reading + 0.2% of full scale) for flow controllers ranging from 5SCCM to 500SLPM with a 200:1 turndown.

You may be able to use a single Alicat controller to control an operating flow range that would normally require two typical mass flow controllers — and still maintain your required accuracy!



MCR 500SLPM

Stand Alone Operation

All Alicat controllers have the ability to operate without a control set-point input signal.

Once the Alicat controller is powered, the control functions can be actuated through the membrane buttons and display screen or through RS-232.

No input set-point signal is required.

The controller will hold the set-point and control at a given flow rate or pressure until loss of power or the set-point is changed.

The set-point is maintained even after a power outage and reboot.

Low Power

Alicat mass flow controllers use significantly less power than most other MFCs in the same flow range. This makes the controllers ideal for limited power applications.

Low power also means low heat – this saves money in multi-unit applications that require the controllers to be placed in tight-fitting enclosures.

MC & MCR Series: Controllers in any flow range from 0 to 0.5SCCM FS through 0 to 3000SLPM FS

MCP Mass Flow Controllers for demanding low pressure applications

Alicat's new MCP units are fitted with a high performance valve that provides increased speed of response and control stability for low pressure applications.

MCP controllers in ranges from 0 to 50SLPM FS through 0 to 250SLPM FS

Please note maximum pressure of 80 PSIG. See page 32 for technical specifications.



MCP Series

NEW Alicat MCQ and MCRQ Units For High Pressure Applications.

The flow rate is dependent on the pressure in that lower pressures will yield lower flow rates. The Q series devices are highly specialized and should only be ordered after consulting Alicat.

MCQ units are calibrated for operation at high pressure. Optimal performance is achieved at higher operating pressures.

Minimum Operating Pressure – 30PSIA

Maximum Operating Pressure – 320PSIA

Now Available:

ATEX / CSA Class 1 Division 2 hazardous environment for Europe, Canada and the U.S.

PROFIBUS DP-V1

DeviceNet

RS-485 Serial Output

MODEL MCV MASS FLOW CONTROLLER with Integrated Positive Shut-off Valve

The Alicat model **MCV** mass flow controller is designed for applications that require tight shut-off such as vacuum coating and sputtering processes. An integrated pneumatic shut-off valve is normally closed and provides positive shut-off of 1×10^{-9} atm sccm/sec Helium max.

The **MCV** uses the same patented laminar flow differential pressure (DP) technology as all Alicat Scientific flow instruments. The result is unparalleled accuracy and response time in applications where speed and accuracy really count.

The Alicat **MCV** will accurately control gas flow rates as low as 0.5 sccm or as high as 20 slpm with *response times of 50 to 100 milliseconds*. — Response times that can greatly improve your end product and help eliminate target poisoning.

Every **MCV** is pre-programmed with calibrations for 30 gases and displays mass flow, volumetric flow, absolute pressure and temperature. The Alicat **MCV** may be programmed directly through the instrument's keypad or remotely via RS-232 (RS-485 also available). Using RS-232 you can communicate with up to 26 units over a single pair of wires.

The **MCV** is powered with a 12 to 30Vdc power supply. Signal input and outputs include 0-5 Vdc, 0-10Vdc, 4-20mA and RS-232 (RS-485, PROFIBUS or DeviceNet options available).

Please see page 31 for MCV technical specifications.

FEATURES & BENEFITS

- ▶ Response time of 50 to 100 milliseconds
- ▶ Flow range from 0.5 sccm to 20 slpm
- ▶ Analog and digital communication standard (PROFIBUS or DeviceNet optional)
- ▶ 30 pre-programmed gas calibrations standard
- ▶ Accuracy of +/- 0.8% of reading +/- 0.2% full scale
- ▶ Optional HIGH ACCURACY of +/- 0.4% of reading +/- 0.2% full scale
- ▶ Operating range of 1/2% to 100%
- ▶ Digital display showing mass flow, volumetric flow, absolute pressure and temperature.
- ▶ NO WARM UP TIME
- ▶ Compact footprint designed for drop-in replacement of other devices
- ▶ Pneumatic shut-off valve provides positive shut-off to 1×10^{-9} atm sccm/sec Helium max
- ▶ **LIFETIME WARRANTY**



Alicat products are supplied with NIST traceable certification and carry the CE mark.

Alicat provides full technical support and low cost recalibration with quick turnaround.

Call or visit us online for orders and more information.

FIND YOUR FLOW AND PRESSURE SOLUTIONS AT ALICAT TODAY!

Technical Data for Micro-Flow and Ultra-Low Flow MC Mass Flow Controllers 0 to 0.5SCCM Full Scale through 0 to 50SCCM Full Scale

The following specifications are for the standard configuration of the product. There are many options available.

Specification	Mass Controller	Description
Accuracy	± (0.8% of Reading + 0.2% of Full Scale)	At calibration conditions after tare
High Accuracy Option	± (0.4% of Reading + 0.2% of Full Scale)	At calibration conditions after tare
Repeatability	± 0.2%	Full Scale
Operating Range	1/2% to 100%	Full Scale
Turndown Ratio	200 : 1	
Typical Response Time	100	Milliseconds (Adjustable)
Standard Conditions (STP)	25°C & 14.696PSIA	Mass Reference Conditions
Operating Temperature	-10 to +50	°Celsius
Zero Shift	0.02%	Full Scale / °Celsius / Atm
Span Shift	0.02%	Full Scale / °Celsius / Atm
Humidity Range	0 to 100%	Non-Condensing
Controllable Flow Rate	102.4%	Full Scale
Maximum Pressure	145	PSIG
Input /Output Signal Digital	Mass Flow, Volumetric Flow, Pressure & Temperature	RS-232 Serial or RS-485 Serial or PROFIBUS or DeviceNet ¹
Input / Output Signal Analog	Mass Flow	0-5Vdc
Optional Input / Output Signal Secondary Analog	Mass Flow, Volumetric Flow, Pressure or Temperature	0-5 Vdc or 0-10Vdc or 4-20mA
Electrical Connections	8 Pin Mini-DIN or DB-15	
Supply Voltage	12 to 30 Vdc (15-30Vdc for 4-20mA outputs)	
Supply Current	0.250Amp	
Mounting Attitude Sensitivity	None	
Warm-up Time	< 1	Second
Wetted Materials ²	303 & 302 Stainless Steel, Viton®, Silicone RTV (Rubber), Glass Reinforced Nylon, Aluminum, Brass, 430FR Stainless Steel, Silicon, Glass.	

1. If selecting PROFIBUS or DeviceNet no analog signal is available. PROFIBUS / DeviceNet units do not have the display. See PROFIBUS or DeviceNet specifications for PROFIBUS or DeviceNet supply voltages and currents.
2. If your application demands a different material, please contact Alicat for available options.

Mechanical Specifications

Full Scale Flow Mass Controller	Mechanical Dimensions	Process Connections ¹	Pressure Drop ² (PSID)
0.5SCCM to 50SCCM	3.9"H x 3.4"W x 1.1"D	M-5 (10-32) Female Thread*	1.0

Units ≤50SCCM F.S. are shipped with M-5 (10-32) Male Buna-N O-ring face seal to 1/8" Female NPT fittings.
These adaptor fittings were selected for customer convenience in process connection. It should be noted that the 1/8" Female NPT introduces additional dead volume. To minimize dead volume, please see [Accessories](#) for the M-5 (10-32) Male to 1/8"OD compression fitting.

1. Compatible with Beswick®, Swagelok® tube, Parker®, face seal, push connect and compression adapter fittings.
2. Venting to atmosphere. Lower Pressure Drops Available, Please contact Alicat.

0.5SCCM to 50SCCM approximate shipping weight: 1.1 lb.

Technical Data for Low Flow MC Mass Flow Controllers

0 to 100SCCM Full Scale through 0 to 20SLPM Full Scale

The following specifications are for the standard configuration of the product. There are many options available.

Specification	Mass Controller	Description
Accuracy	± (0.8% of Reading + 0.2% of Full Scale)	At calibration conditions after tare
High Accuracy Option	± (0.4% of Reading + 0.2% of Full Scale)	At calibration conditions after tare
Repeatability	± 0.2%	Full Scale
Operating Range	1/2% to 100%	Full Scale
Turndown Ratio	200 : 1	
Typical Response Time	100	Milliseconds (Adjustable)
Standard Conditions (STP)	25°C & 14.696PSIA	Mass Reference Conditions
Operating Temperature	-10 to +50	°Celsius
Zero Shift	0.02%	Full Scale / °Celsius / Atm
Span Shift	0.02%	Full Scale / °Celsius / Atm
Humidity Range	0 to 100%	Non-Condensing
Controllable Flow Rate	102.4%	Full Scale
Maximum Pressure	145	PSIG
Input /Output Signal Digital	Mass Flow, Volumetric Flow, Pressure & Temperature	RS-232 Serial or RS-485 Serial or PROFIBUS or DeviceNet ¹
Input / Output Signal Analog	Mass Flow	0-5Vdc
Optional Input / Output Signal Secondary Analog	Mass Flow, Volumetric Flow, Pressure or Temperature	0-5 Vdc or 0-10Vdc or 4-20mA
Electrical Connections	8 Pin Mini-DIN or DB-15	
Supply Voltage	12 to 30 Vdc (15-30Vdc for 4-20mA outputs)	
Supply Current	0.250Amp (at 12 Vdc, declining with increased supply voltage)	
Mounting Attitude Sensitivity	None	
Warm-up Time	< 1	Second
Wetted Materials ²	303 & 302 Stainless Steel, Viton®, Silicone RTV (Rubber), Glass Reinforced Nylon, Aluminum, Brass, 430FR Stainless Steel, Silicon, Glass.	

1. If selecting PROFIBUS or DeviceNet no analog signal is available. PROFIBUS / DeviceNet units do not have the display. See PROFIBUS or DeviceNet specifications for PROFIBUS or DeviceNet supply voltages and currents.
2. If your application demands a different material, please contact Alicat for available options.

Mechanical Specifications

Full Scale Flow Mass Controller	Mechanical Dimensions	Process Connections ¹	Pressure Drop ² (PSID)
100SCCM to 500SCCM	4.1"H x 3.6"W x 1.1"D	1/8" NPT Female	1.0
1SLPM			1.5
2SLPM			3.0
5SLPM			2.0
10SLPM			5.5
20SLPM			20.0

1. Compatible with Beswick®, Swagelok® tube, Parker®, face seal, push connect and compression adapter fittings.
2. Lower Pressure Drops Available, Please contact Alicat.

100SCCM to 20SLPM approximate weight: 1.2lb

Technical Data for Moderate Flow MC Mass Flow Controllers

0 to 50SLPM Full Scale through 0 to 100SLPM Full Scale

The following specifications are for the standard configuration of the product. There are many options available.

Specification	Mass Controller	Description
Accuracy	± (0.8% of Reading + 0.2% of Full Scale)	At calibration conditions after tare
High Accuracy Option	± (0.4% of Reading + 0.2% of Full Scale)	At calibration conditions after tare
Repeatability	± 0.2%	Full Scale
Operating Range	1/2% to 100%	Full Scale
Turndown Ratio	200 : 1	
Typical Response Time	100	Milliseconds (Adjustable)
Standard Conditions (STP)	25°C & 14.696PSIA	Mass Reference Conditions
Operating Temperature	-10 to +50	°Celsius
Zero Shift	0.02%	Full Scale / °Celsius / Atm
Span Shift	0.02%	Full Scale / °Celsius / Atm
Humidity Range	0 to 100%	Non-Condensing
Controllable Flow Rate	102.4%	Full Scale
Maximum Pressure	145	PSIG
Input /Output Signal Digital	Mass Flow, Volumetric Flow, Pressure & Temperature	RS-232 Serial or RS-485 Serial or PROFIBUS or DeviceNet ¹
Input / Output Signal Analog	Mass Flow	0-5Vdc
Optional Input / Output Signal Secondary Analog	Mass Flow, Volumetric Flow, Pressure or Temperature	0-5 Vdc or 0-10Vdc or 4-20mA
Electrical Connections	8 Pin Mini-DIN or DB-15	
Supply Voltage	24 to 30 Vdc	
Supply Current	0.750Amp	
Mounting Attitude Sensitivity	Control response somewhat sensitive to inverted operation.	
Warm-up Time	< 1	Second
Wetted Materials ²	303 & 302 Stainless Steel, Viton®, Silicone RTV (Rubber), Glass Reinforced Nylon, Aluminum, 416 Stainless Steel, Nickel, Silicon, Glass.	

1. If selecting PROFIBUS or DeviceNet no analog signal is available. PROFIBUS / DeviceNet units do not have the display. See PROFIBUS or DeviceNet specifications for PROFIBUS or DeviceNet supply voltages and currents.
2. If your application demands a different material, please contact Alicat for available options.

Mechanical Specifications

Full Scale Flow Mass Controller	Mechanical Dimensions	Process Connections ¹	Pressure Drop ² (PSID)
50SLPM	4.4"H x 6.4"W x 2.3"D	1/4" NPT Female	9.0
100SLPM			11.7

1. Compatible with Beswick®, Swagelok® tube, Parker®, face seal, push connect and compression adapter fittings.
2. Lower Pressure Drops Available, Please contact Alicat.

50SLPM to 100SLPM approximate weight: 6.4 lb.

Technical Data for High Flow MCR Mass Flow Controllers

0 to 100SLPM Full Scale through 0 to 3000SLPM Full Scale

The following specifications are for the standard configuration of the product. There are many options available.

Specification	Mass Controller	Description
Accuracy	± (0.8% of Reading + 0.2% of Full Scale)	At calibration conditions after tare
High Accuracy Option ¹	± (0.4% of Reading + 0.2% of Full Scale)	At calibration conditions after tare
Repeatability	± 0.2%	Full Scale
Operating Range	1/2% to 100%	Full Scale
Turndown Ratio	200 : 1	
Typical Response Time	100	Milliseconds (Adjustable)
Standard Conditions (STP)	25°C & 14.696PSIA	Mass Reference Conditions
Operating Temperature	-10 to +50	°Celsius
Zero Shift	0.02%	Full Scale / °Celsius / Atm
Span Shift	0.02%	Full Scale / °Celsius / Atm
Humidity Range	0 to 100%	Non-Condensing
Controllable Flow Rate	102.4%	Full Scale
Maximum Pressure	145	PSIG
Input /Output Signal Digital	Mass Flow, Volumetric Flow, Pressure & Temperature	RS-232 Serial or RS-485 Serial or PROFIBUS or DeviceNet ¹
Input / Output Signal Analog	Mass Flow	0-5Vdc
Optional Input / Output Signal Secondary Analog	Mass Flow, Volumetric Flow, Pressure or Temperature	0-5 Vdc or 0-10Vdc or 4-20mA
Electrical Connections	8 Pin Mini-DIN or DB-15	
Supply Voltage	24 to 30 Vdc	
Supply Current	0.750Amp	
Mounting Attitude Sensitivity	Control response somewhat sensitive to inverted operation.	
Warm-up Time	< 1	Second
Wetted Materials ³	303 & 302 Stainless Steel, Viton®, Silicone RTV (Rubber), Glass Reinforced Nylon, Aluminum, 416 Stainless Steel, Nickel, Silicon, Glass.	

1. High Accuracy option not available for units ranged over 500SLPM.

2. If selecting PROFIBUS or DeviceNet no analog signal is available. PROFIBUS / DeviceNet units do not have the display. See PROFIBUS or DeviceNet specifications for PROFIBUS or DeviceNet supply voltages and currents.

3. If your application demands a different material, please contact Alicat for available options.

Mechanical Specifications

Full Scale Flow Mass Controller	Mechanical Dimensions	Process Connections ¹	Pressure Drop ² (PSID)
100SLPM	5.5"H x 7.7"W x 2.3"D	1/4" NPT Female	2.6
250SLPM	5.5"H x 7.7"W x 2.3"D	1/2" NPT Female	4.6
500SLPM	5.5"H x 7.4"W x 2.3"D	3/4" NPT Female	6.5
1000SLPM			14.0
1500SLPM			17.0
2000SLPM	5.5"H x 8.1" W x 2.9" D	1-1/4" NPT Female	28.6
3000SLPM	5.5"H x 8.9" W x 2.9" D		16.8

- Compatible with Beswick®, Swagelok® tube, Parker®, face seal, push connect and compression adapter fittings.
- Venting to atmosphere. Lower Pressure Drops Available, Please contact Alicat.

MCR-250SLPM to 1500SLPM approximate weight: 9.0 lb.
MCR-2000SLPM to 3000SLPM approximate weight: 12.0 lb.

Technical Data for **MCV** Mass Flow Controller with Integrated Positive Shut-off Valve
0 to 0.5SCCM Full Scale through 0 to 20SLPM Full Scale

Specification	MCV Mass Controller	Description
Accuracy	± (0.8% of Reading + 0.2% of Full Scale)	At calibration conditions after tare
High Accuracy Option ¹	± (0.4% of Reading + 0.2% of Full Scale)	At calibration conditions after tare
Repeatability	± 0.2%	Full Scale
Operating Range	1/2% to 100%	Full Scale
Turndown Ratio	200 : 1	
Typical Response Time	100	Milliseconds (Adjustable)
Standard Conditions (STP)	25°C & 14.696PSIA	Mass Reference Conditions
Operating Temperature	-10 to +50	°Celsius
Zero Shift	0.02%	Full Scale / °Celsius / Atm
Span Shift	0.02%	Full Scale / °Celsius / Atm
Humidity Range	0 to 100%	Non-Condensing
Controllable Flow Rate	102.4%	Full Scale
Maximum Pressure	145	PSIG
Input /Output Signal Digital	Mass Flow, Volumetric Flow, Pressure & Temperature	RS-232 Serial or RS-485 Serial or PROFIBUS or DeviceNet ²
Input / Output Signal Analog	Mass Flow	0-5Vdc
Optional Input / Output Signal Secondary Analog	Mass Flow, Volumetric Flow, Pressure or Temperature	0-5 Vdc or 0-10Vdc or 4-20mA
Electrical Connections	8 Pin Mini-DIN or DB-15	
Supply Voltage	12 to 30 Vdc (15-30Vdc for 4-20mA outputs)	
Supply Current	0.300Amp	
Mounting Attitude Sensitivity	None	
Warm-up Time	< 1	Second
Integrated Valve Leak Integrity	1 x 10 ⁻⁹ atm sccm/sec Helium max	
Wetted Materials ³	316L,303 & 302 Stainless Steel, Viton®, Silicone RTV (Rubber), Glass Reinforced Nylon, Aluminum, Brass, 430FR Stainless Steel, Silicon, Glass, PCTFE.	

1. High Accuracy Option not available for ranges below 5SCCM.
 2. If selecting PROFIBUS or DeviceNet no analog signal is available. PROFIBUS / DeviceNet units do not have the display. See PROFIBUS or DeviceNet specifications for PROFIBUS or DeviceNet supply voltages and currents.
 3. If your application demands a different material, please contact Alicat for available options.

Full Scale Flow MCV Controller	Mechanical Dimensions	Process Connections
0.5SCCM to 20SLPM	4.8"H x 6.8"W x 1.5"D	1/4" VCR® Male

Welded VCR® fittings (process connections) are recommended for MCV applications. Please contact Alicat.

MCV Series
All ranges

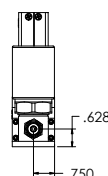
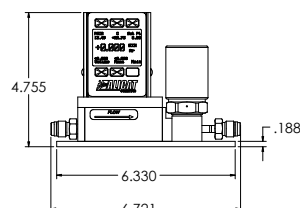
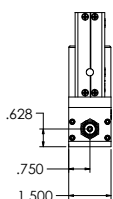
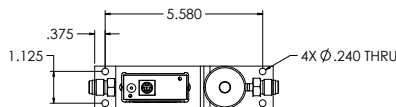

MCV approximate weight: 3.0 lb.

Technical Data for MCP Moderate Flow Mass Flow Controllers

0 to 50SLPM Full Scale through 0 to 250SLPM Full Scale

NOTICE: The following specifications are applicable to Alicat MCP Series Mass Flow Controllers only.
Please note maximum pressure of 80 PSIG.

Specification	MCP Mass Controller	Description
Accuracy	± (0.8% of Reading + 0.2% of Full Scale)	At calibration conditions after tare
High Accuracy Option	± (0.4% of Reading + 0.2% of Full Scale)	At calibration conditions after tare
Repeatability	± 0.2%	Full Scale
Operating Range	1/2% to 100%	Full Scale
Turndown Ratio	200 : 1	
Typical Response Time	100	Milliseconds (Adjustable)
Standard Conditions (STP)	25°C & 14.696PSIA	Mass Reference Conditions
Operating Temperature	-10 to +50	°Celsius
Zero Shift	0.02%	Full Scale / °Celsius / Atm
Span Shift	0.02%	Full Scale / °Celsius / Atm
Humidity Range	0 to 100%	Non-Condensing
Controllable Flow Rate	102.4%	Full Scale
Maximum Pressure	80	PSIG
Input /Output Signal Digital	Mass, Volumetric, Pressure & Temperature	RS-232 Serial or RS-485 Serial or PROFIBUS or DeviceNet
Input / Output Signal Analog	Mass Flow	0-5Vdc
Optional Input / Output Signal Secondary Analog	Mass, Volumetric, Pressure or Temperature	0-5 Vdc or 0-10Vdc or 4-20mA
Electrical Connections	8 Pin	Mini-DIN
Supply Voltage	12 to 30 Vdc	
Supply Current	0.250Amp	
Mounting Attitude Sensitivity	None	
Warm-up Time	< 1	Second
Wetted Materials ²	303 & 302 Stainless Steel, Viton®, Silicone RTV (Rubber), Glass Reinforced Nylon, Aluminum, Brass, 410 & 416 Stainless Steel.	

1. If your application demands a different material, please contact Alicat for available options.

Mechanical Specifications

Full Scale Flow MCP Mass Controller	Mechanical Dimensions	Process Connections ¹	Pressure Drop ² (PSID)
50SLPM	4.4"H x 5.4"W x 1.6"D	1/4" NPT Female	6.0
100SLPM			14.0
250SLPM	5.0"H x 6.0"W x 1.6"D	1/4" and 1/2" NPT Female	

1. Compatible with Beswick®, Swagelok® tube, Parker®, face seal, push connect and compression adapter fittings.

2. Lower Pressure Drops Available, Please contact Alicat.

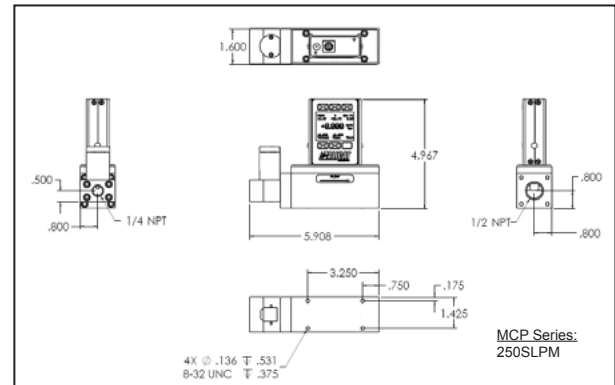
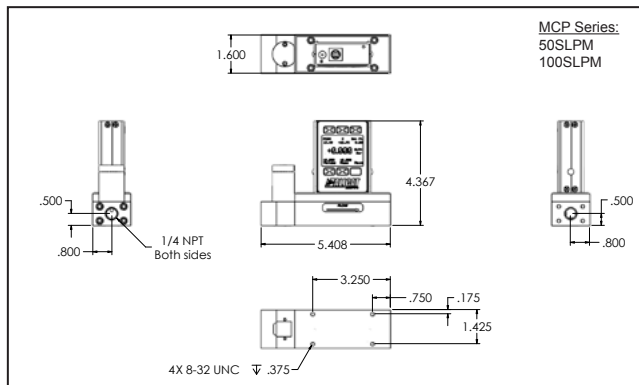

MC, MCR and MCP Dimensional Drawings

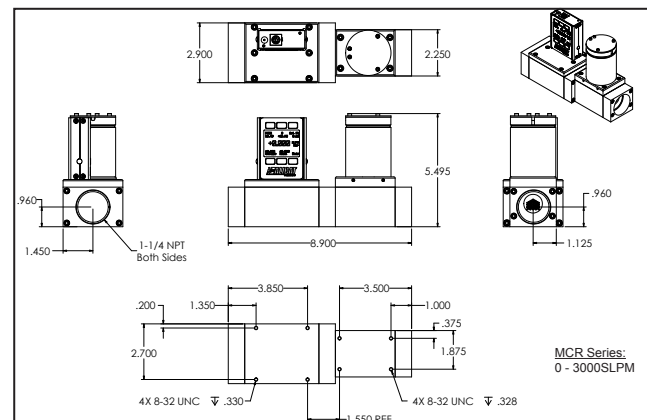
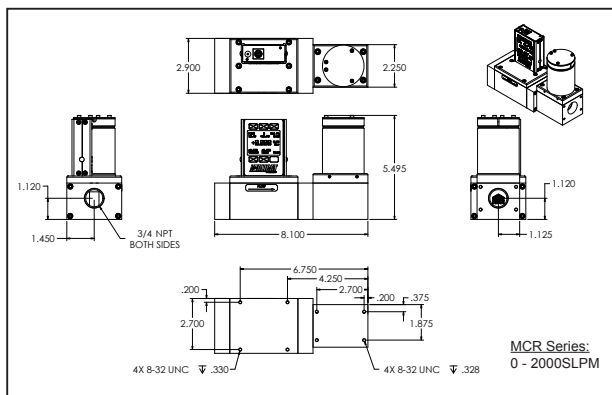
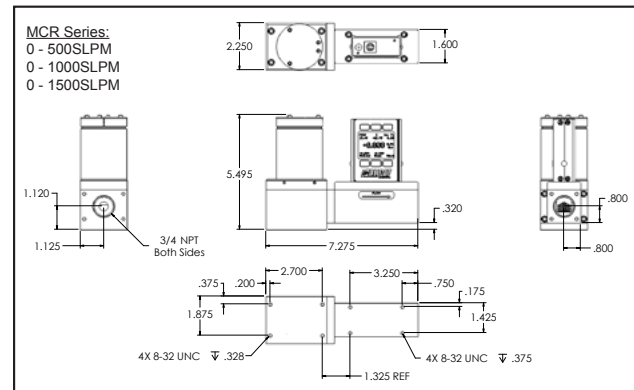
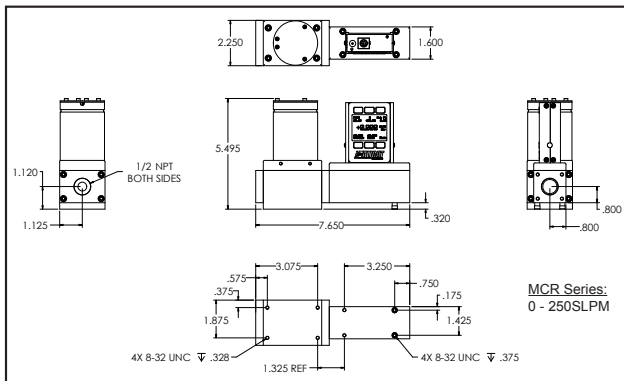
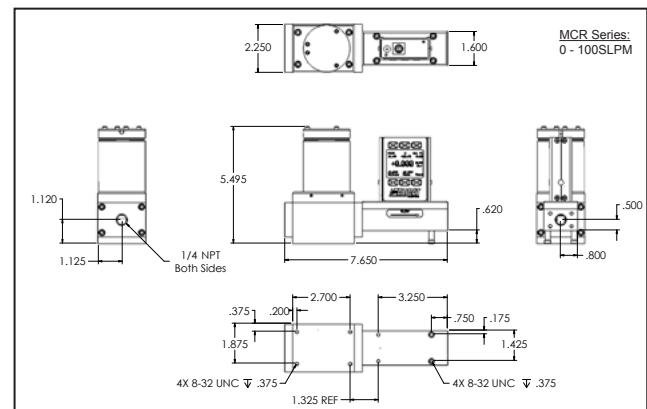
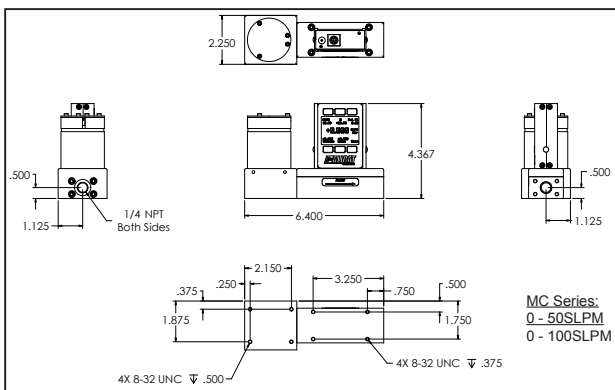
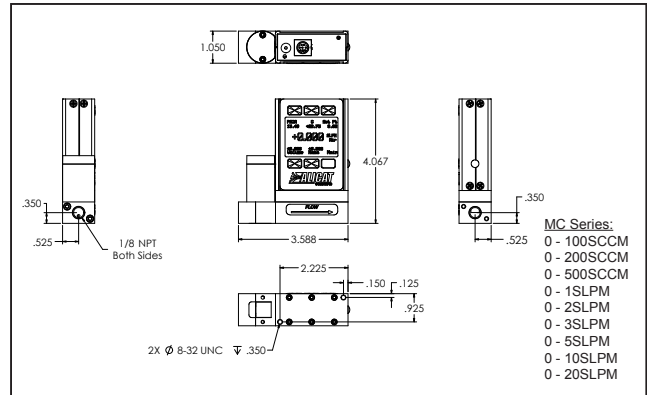
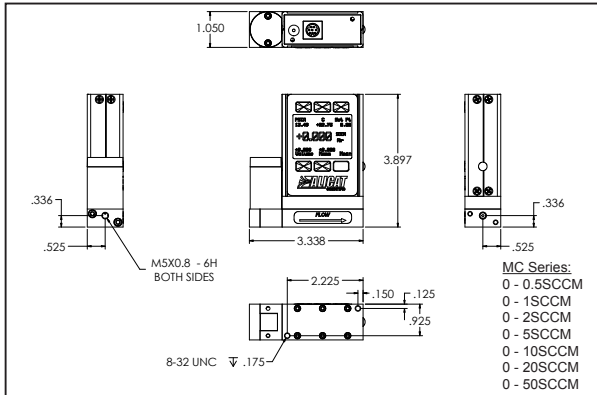

Technical Data for Alicat MCS and MCRS Series Mass Flow Controllers

Alicat MCS and MCRS instruments are built for use with aggressive gases. For the most part these instruments maintain the specifications of equivalently ranged MC and MCR Series devices.

In addition to Alicat’s standard 30 gas select programming, MCS and MCRS controllers are configured to operate with the following aggressive gases.

MCS controller gas compatibility list :

NO	Nitric Oxide to 100%
NF3	Nitrogen Trifluoride to 100%
NH3	Ammonia to 100%
H2S	Hydrogen Sulfide to 100% (22°C and under)
Propylene	to 100%

In addition, the following gases are available upon request:

NO2	Nitrogen Dioxide to 0.5% in an inert carrier
Refrigerant gases	to 100%
Other gases	to 1000 ppm in an inert carrier

If your application requires another gas or gas mixture, please contact Alicat. We will do our best to accommodate your request.

Please refer to Alicat’s Technical Data and Specifications for the equivalently ranged MC and MCR Series instrument for all operating specifications except:

Operating Range	1% to 100%	Full Scale
Turndown Ratio	100 : 1	
Wetted Materials	316LSS, 303SS, 430FRSS, FFKM (Kalrez) standard, Viton, EPDM as needed for some gases.	

The dimensions of MCS and MCRS instruments may vary from their standard MC and MCR Series counterparts. Dimensional drawings for MCS and MCRS instruments are shown on page 35.



We want your input!

***If you have any suggestions, ideas or concerns regarding any Alicat product —
Please contact us at: feedback@alicatescientific.com.***

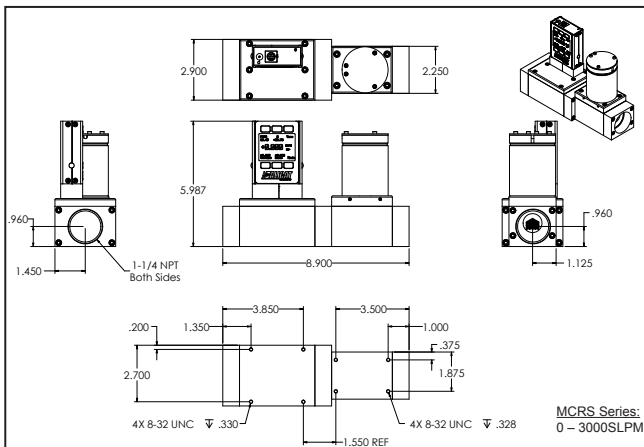
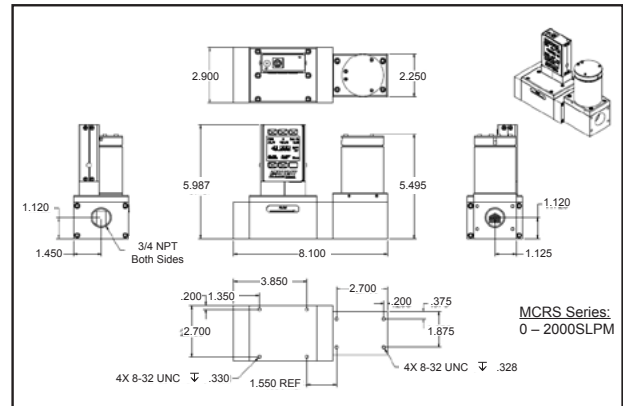
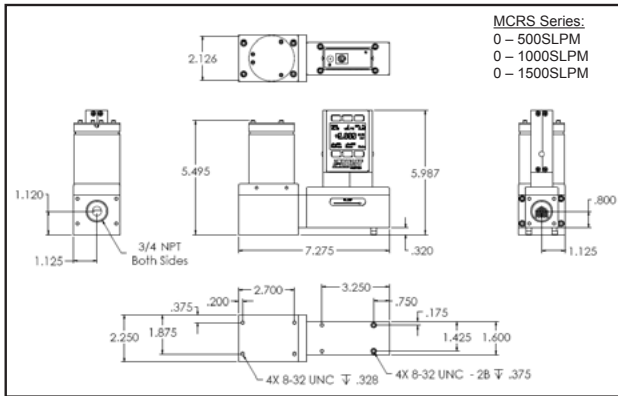
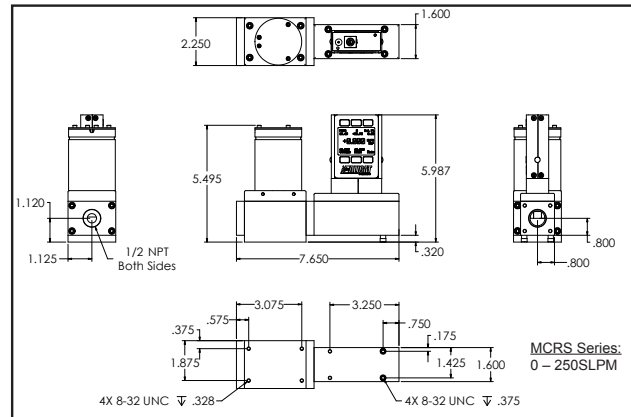
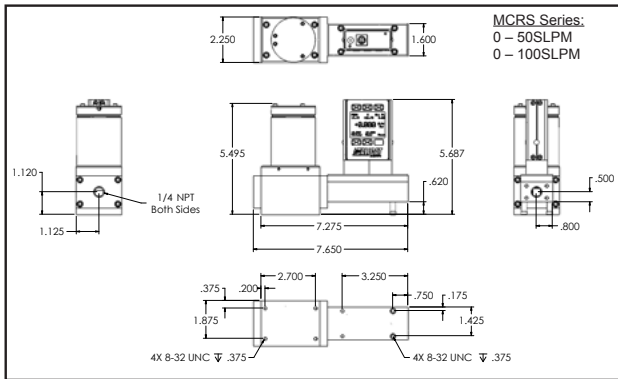
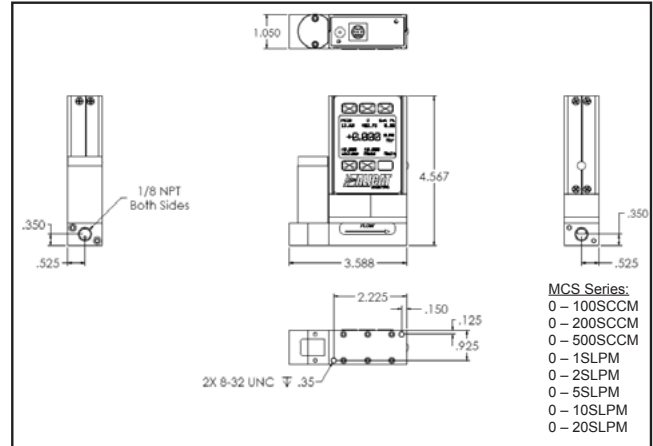
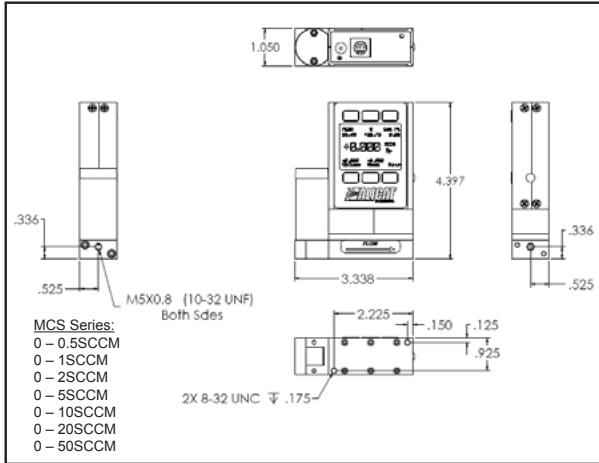

DIGITAL PRESSURE GAUGES and CONTROLLERS for Gas and Water

Extraordinary Pressure and Vacuum Measurement and Control!

Alicat digital pressure gauges and controllers utilize multiple configurations to perform and solve pressure needs in all types of gas and water applications.

Our pressure instruments are designed specifically for demanding applications like vacuum coating or leak testing, where accuracy and stability of pressure measurement and control can make the difference between success and failure.

Whether you are controlling low vacuum, measuring pressures up to 500 PSI, working with closed volumes, flow through pressure or performing back pressure control – *the versatility of Alicat pressure instruments means that one of our devices can be custom-tailored to fit your needs and resolve your process concerns.*

Because water is about 50 times more viscous than air, please consult our engineers for sizing and PID tuning specifics if you intend to use your pressure device with water or another fluid.



PCD Series

Accurate, Repeatable and Fast

Alicat pressure gauges and controllers are an economical answer to form, fit and function — with $\pm 0.25\%$ or $\pm 0.5\%$ accuracy (depending on range), $\pm 0.08\%$ repeatability and a control response time of 100ms or less. High accuracy calibration of $\pm 0.125\%$ of full scale is available for most ranges.

Alicat's impressive input/output options let you regulate processes with simple digital or analog signals via the onboard PID loop controller

Although the instruments come well-tuned from the factory, you can optimize performance in the field by adjusting the P and D through either the front panel display or through RS-232 which is standard on all Alicat instruments.

Digital Pressure Control in Place of Pneumatic Pressure Control Valves

Alicat's pressure controllers use true, highly efficient proportional control valves.

Unlike traditional pneumatic pressure control valves, our digital pressure controllers give you precise control of your process.

These valves adjust to the exact position necessary to achieve the desired pressure set-point and they will maintain that pressure for extended periods of time.

Their low-friction, fast-moving design achieves set-point changes in 100ms or less.

Pressure and Vacuum Gauges and Controllers for Aggressive Gases

Alicat Pressure instruments are now available for use with a number aggressive gases. Please see page 45 for more information.

New at Alicat: PC-ExtSen — External Sensor Pressure Controllers

Call Alicat for more information and application assistance.



PCR Series

Alicat Pressure Devices Are Available In Any of Nine Different Units Of Measure!

PSIA	PSIG	mmHG	inHG	inH ₂ O	mBar	Atm	Torr	kPa
------	------	------	------	--------------------	------	-----	------	-----

DIGITAL PRESSURE GAUGES and CONTROLLERS

Stand Alone Operation

All Alicat pressure controllers have the ability to operate without a control set-point input signal.

Once the controller is powered, the control functions can be actuated through the membrane buttons and display screen or through RS-232.

No input set-point signal is required.

The controller will hold the set-point and control at a given flow rate or pressure until loss of power or the set-point is changed.

The set-point is maintained even after a power outage and reboot.



PC3 Series

Easily Integrated into OEM Systems

Alicat's small footprint and multiple communication platforms make it the perfect device for OEM applications that require vacuum and/or positive pressure measurement and control.

Your Alicat pressure controller can be ordered with an external pressure sense port – allowing the device to measure and control pressure at any point in your system. This may permit measurement and control in areas that would otherwise be impossible to maintain.

The Alicat pressure controller can receive analog signals from other pressure or vacuum sensing devices. An example of this would be high vacuum control in an ion chamber using the output signal from an existing ion high vacuum gauge.

Separated sensor and valve configurations can be provided to overcome spatial restrictions in high flow pressure control applications.

PRESSURE DEVICE CAPABILITIES	P	PC	PCR	PC3	PCR3	PCD	PCDR	PCD3	PCDR3	PCM	MC*	MCR*
Differential Pressure	◆	◆	◆	◆	◆	◆	◆	◆	◆	◆		
Vacuum	◆	◆	◆	◆	◆	◆	◆	◆	◆			
Back Pressure		◆	◆	◆	◆						◆	◆
Gauge Pressure	◆	◆	◆	◆	◆	◆	◆	◆	◆	◆		
Absolute Pressure	◆	◆	◆	◆	◆	◆	◆	◆	◆	◆	◆	◆
Flow Through Pressure	◆	◆	◆	◆	◆					◆	◆	◆
Closed System — Pressure or Vacuum	◆					◆	◆	◆	◆			
Remote Pressure (External Feedback)				◆	◆			◆	◆			
Portable Digital Gauging	◆											
High Flow >20LPM			◆		◆		◆		◆			◆

*Alicat's MC & MCR mass gas flow controllers can function as pressure controllers in applications where users are concerned with monitoring mass or volumetric flow rate while controlling pressure. Please see page 25.

Now Available: ATEX / CSA Class 1 Division 2 hazardous environment for Europe, Canada and the U.S.
 PROFIBUS DP-V1 DeviceNet RS-485 Serial Output

DIGITAL PRESSURE GAUGES and CONTROLLERS

P Series

Digital Pressure Gauges

Pressure measurements as low as -30inHG full scale to as high as 500PSI.

Alicat manufactures absolute Pressure gauges ranging from 800mmHG full scale to as high as 500PSIA that can operate on 7 to 30Vdc. All gauges include a display combined with analog and digital communications output.

The gauges are designed to seamlessly integrate with our flow products on one RS-232 line. This decreases time and expense in applications that require flow and pressure measurement in different physical locations of the system, but with the same Programmable Logic Controller (PLC). A portable pressure gauge which operates on a standard 9Vdc battery is also available (see page 40).



P Series

PC Series

Single Valve Pressure Controllers

Available in multiple configurations, the versatility of the **PC** Series allows you to control absolute pressures, gauge pressures, back pressures, and vacuum pressures.

The speed of response and stability of these digital devices offer many advantages over more common mechanical controllers. Like all Alicat instruments analog and digital communication is standard.

With 1/8th inch female NPT connection ports, the **PC** performs in-line flow through pressure control with standard $\pm 0.25\%$ full scale accuracy. Optional high accuracy calibration to $\pm 0.125\%$ FS is available on most ranges.



PC Series

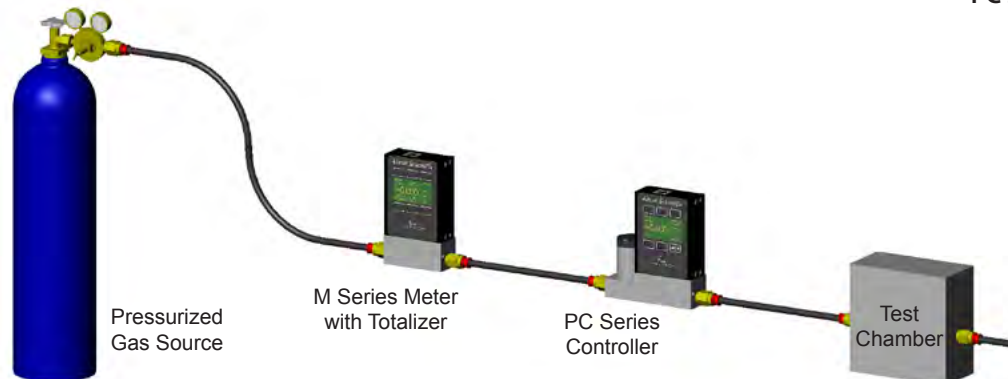

Many gas blanketing and biomedical research applications require gas flow over a target material or test bed at a given pressure. Alicat Scientific's **PC** series in its standard configuration controls pressure in the blanketing or test chamber while an Alicat **M** series mass flow meter with optional totalizer monitors and records the total flow rate through the test area.

P & PC Series: Differential Pressure Gauges and Controllers

Differential pressure gauges measure a pressure differential between two points in a process line.

Differential pressure controllers increase or restrict the flow in a process in order to control the pressure difference between two points in the line.

There are a variety of applications for these devices. One of the most common is to measure or control the difference in pressure across a filter element over time or to test the filter element efficiency.

Please contact Applications Assistance for more differential pressure information.

DIGITAL PRESSURE GAUGES and CONTROLLERS

PCR Series: High Flow Pressure Controllers

PCR Series single valve pressure controllers perform flow through pressure control in high flow applications (flows greater than 20 LPM).

The **PCR** series utilizes the Alicat **LRV** (low pressure drop valve) which is specially designed for applications requiring high mass flow rates at positive pressure or in vacuum applications with high volumetric flow rates.

With 3/4 inch female NPT connection ports, the **PCR** performs in-line flow through pressure control with typical $\pm 0.25\%$ full scale accuracy and fast response.



PCR Series

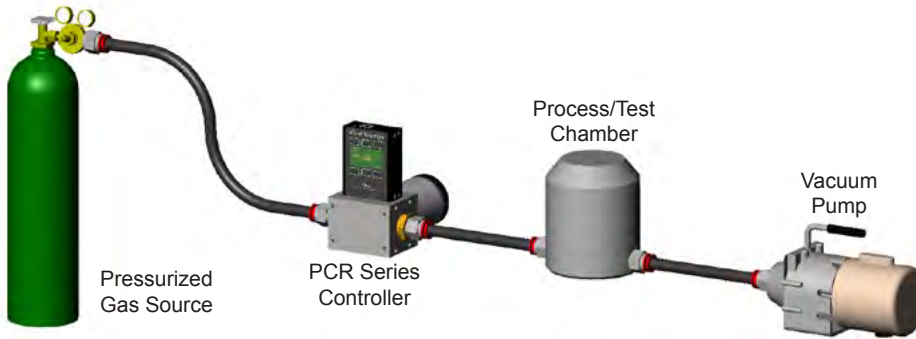

High Flow Vacuum & Positive Pressure Control with Alicat PCR Series

PC3 & PCR3 Series: External Pressure Port Controllers

PC3 Series single valve pressure controllers are fitted with an external pressure port for sensing and controlling pressures at a remote point in the system.

A very common application for the **PC3**, is as a leak checking instrument where maintaining a precise pressure at the testing orifice is critical.

In another application of the **PC3**, Alicat utilized multiple pressure sensors in various ranges, performing the functions of a vacuum gauge and a positive pressure controller in one device.

For High flow rates Alicat offers the **PCR3** Series which utilizes the Alicat **LRV** control valve.



PC3 Series

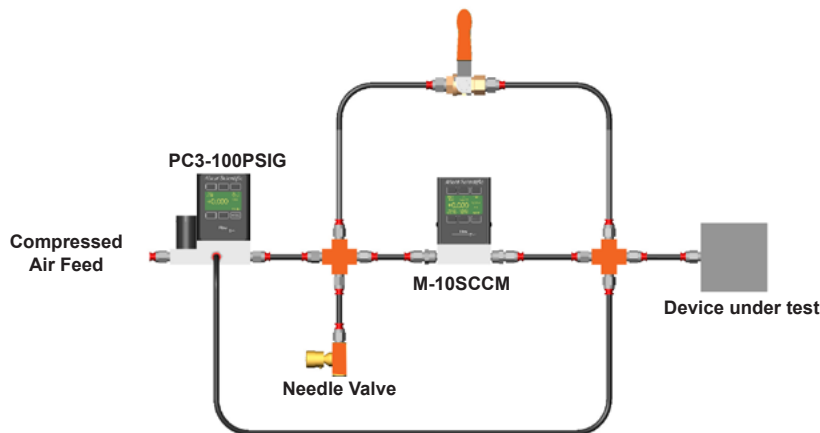

Leak Test with Alicat PC3 and M Series

See page 57 "Faster Leak Checking"

DIGITAL PRESSURE GAUGES and CONTROLLERS

PC Series: External Ion Gauge Vacuum Controllers

The *External Ion Gauge Vacuum Controller* was designed specifically for the vacuum coating industry.

This innovation circumvents the low end range of our pressure sensors and allows for control of extreme vacuum conditions in the coating chamber.

The controller provides lightning fast control based on data provided by an ion gauge vacuum sensor with a linear 0-10 volt output of pressure. The controller translates the signal and precisely controls vacuum conditions within the process chamber. Please see page 50 for more information.

PCD Series: Dual Valve Pressure Controllers

The **PCD** Dual Valve Pressure Controller accurately and efficiently controls pressure within a closed system with minimum loss of expensive gases through the exhaust process.

Gases are exhausted only when over pressurization is detected and released with little waste. This is critical when trying to maintain precise and repeatable pressure on valves or fittings during leak tests and is crucial for extending the life of your bottle gas supply.

PCD's can be used for pressure loading on fluid dispensers such as paint delivery processes or systems that require precise application of forces for pressure controlled actuation.

Additionally, all feed and exhaust valve adjustments are done internally through the **PCD** logic reducing processing time. This can help to free up control requirements on higher level PLCs or DCS systems, increasing speed and efficiency, while still allowing them to access data for monitoring, logging and recording of the process.

PCD for Closed Volume Pressure Control

The dual valve pressure controller is maintaining a precise pressure of medical grade helium within a closed volume.

Product within the chamber is undergoing a coating process which requires a specific pressure set-point at different intervals.

The **PCD** maintains the set-point while reducing the use of helium. The ability to reliably and consistently maintain specific pressures within the chamber increases yields and improves the quality of the end product.

The reduction in gas usage translates directly into significant savings, especially in expensive bottled gas systems.



PCM Series: Manifold Pressure Controllers

PCM Series manifold pressure controllers are custom-built for multiple pressure control OEM applications.

The **PCM** manifold incorporates an array of dual-valve pressure controllers of up to 11 units per system.

These unique custom-built devices have been utilized by bio-medical researchers and semiconductor equipment manufacturers for precise proportional based pressure control of fluidic movement through micro-flow channels or chambers.

The mechanics of the **PCM** simplifies plumbing, while the RS-232 communication protocol consolidates electronic communications into a single simple RS-232 transmit and receive connection that communicates with all of the individual pressure controllers simultaneously.

Other configurations of **PCM's** incorporate pressure gauges in place of some of the pressure controllers for monitoring pressure at non-control points in the system.

All units in a **PCM** are configured to the volumes being controlled and the pressure ranges required (as compatible with specs on **PCD** series: Dual Valve Pressure Controllers and **P** series: Pressure Gauges).

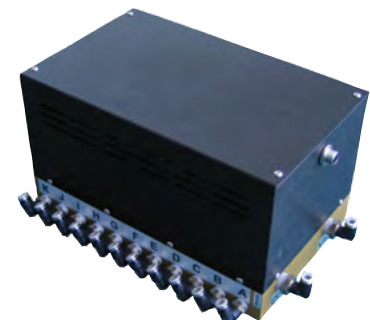

PCM Series

Technical Data for Pressure Gauges and Single Valve Pressure Controllers

The following specifications are for the standard configuration of the product. There are many customization options available. PCR Series high flow pressure controllers are for applications with required flows above 20LPM. Please contact Alicat for additional PCR operating specifications.

Operating Specifications

Specification	P Series	PC & PCR Series	Description
Full scale pressure < 2" H2O Accuracy	Consult Factory		Full Scale
Full scale pressure ≥ 2" H2O Standard Accuracy	± 0.25%		Full Scale
Full scale pressure ≥ 2" H2O High Accuracy Option	± 0.125%		Full Scale
Repeatability	± 0.08%		Full Scale
Turndown Ratio	200:1		
Adjustable Response Time ¹	5	100	Milliseconds
Operating Temperature	-10 to +50		Degree Celsius
Zero Shift	0.02%		Full Scale / °Celsius
Span Shift	0.02%		Full Scale / °Celsius
Excess Pressure	128% Measurable	102.4% Controllable	Full Scale
Burst Pressure	3X		Full Scale
Supply Current Peak	0.035	0.250 (PCR: 0.750)	Amp
Supply Voltage	7 – 30	12 – 30 (PCR Series = 24 – 30)	Volts dc
Input /Output Signal Standard	RS-232 or RS-485 Serial & 0-5Vdc or PROFIBUS or DeviceNet ²		
Electrical Connections	8 Pin Mini-DIN or DB-15		
Wetted Materials ³	302 & 303 Stainless Steel, Viton®, Silicone RTV, Silicon, Glass. All Controllers add: 400 Series Stainless Steel. PC Series Controllers only add: Brass		

1. Volumes, feed pressures, exhaust pressures and line sizing will determine the limits of response times.
 2. If selecting PROFIBUS or DeviceNet no analog signal is available. PROFIBUS and DeviceNet units do not have the display. See PROFIBUS or DeviceNet specifications for supply voltages and supply currents.
 3. If your application demands a different material, please contact Alicat for available options.

Mechanical Specifications

Pressure Product	Mechanical Dimensions	Process Connections ¹
P Series Gauges	4.1"H x 2.4"W x 1.1"D	1/8" NPT Female
PC Series Controllers	4.1"H x 3.6"W x 1.1"D	1/8" NPT Female
PCR Series Controllers	5.5"H x 2.9"W x 5.5"D	3/4" NPT Female

1. Compatible with Swagelok® tube, Parker®, face seal, push connect & compression adapter fittings. Alternates available.

Standard Available Ranges

P Series Gauges			PC, PCR Series Controllers		
-15PSIG to 0PSIG			-15PSIG to 0PSIG		
2inH ₂ OD	2inH ₂ OG		2inH ₂ OD	2inH ₂ OG	
4inH ₂ OD	4inH ₂ OG		4inH ₂ OD	4inH ₂ OG	
1PSID	1PSIG		1PSID	1PSIG	
5PSID	5PSIG		5PSID	5PSIG	
15PSID	15PSIG	15PSIA	15PSID	15PSIG	15PSIA
30PSID	30PSIG	30PSIA	30PSID	30PSIG	30PSIA
100PSID	100PSIG	100PSIA	100PSID	100PSIG	100PSIA
150PSID		300PSIA	150PSID		300PSIA

Other ranges available. Please contact Alicat.

Select One Unit of Measure when Ordering		
PSIA	inHG	Atm
PSIG	inH ₂ O	Torr
mmHG	mBar	kPa

Technical Data for Dual Valve Pressure Controllers

The following specifications are for the standard configuration of the product. There are many customization options available.

Operating Specifications

Specification	PCD Series	Description
Full scale pressure < 2" H2O Accuracy	Consult Factory	Full Scale
Full scale pressure ≥ 2" H2O Standard Accuracy	± 0.25%	Full Scale
Full scale pressure ≥ 2" H2O High Accuracy Option	± 0.125%	Full Scale
Feed Valve Orifice	0.050 ¹	Inches
Exhaust Valve Orifice	0.050 ¹	Inches
Alternate Valve Orifices Available	0.010 or 0.030	Inches
Repeatability	± 0.08%	Full Scale
Turndown Ratio	200:1	
Adjustable Response Time ²	≤100	Milliseconds
Operating Temperature	-10 to +50	Degree Celsius
Zero Shift	0.02%	Full Scale / °Celsius
Span Shift	0.02%	Full Scale / °Celsius
Excess Pressure	102.4% Controllable	Full Scale
Burst Pressure	≥3X	Full Scale
Supply Current Peak	0.250	Amp
Supply Current Average	0.050	Amp
Supply Voltage	12 – 30	Volts dc
Input /Output Signal Standard	RS-232 Serial & 0-5Vdc or PROFIBUS or DeviceNet ³	
Electrical Connections	8 Pin Mini-DIN or DB-15	
Wetted Materials ⁴	302 & 303 Stainless Steel, Viton®, Silicone RTV, Brass, 400 Series Stainless Steel (standard units are for non-corrosive gases), Silicon, Glass.	

1. Other sizes may be selected based upon process requirements
2. Volumes, feed pressures, exhaust pressures and line sizing will determine the limits of response times.
3. If selecting PROFIBUS or DeviceNet no analog signal is available. PROFIBUS and DeviceNet units do not have the display. See PROFIBUS or DeviceNet specifications for supply voltages and supply currents. Please contact Applications Assistance for PCD - PROFIBUS or DeviceNet options.
4. If your application demands a different material, please contact Alicat for available options.

PCD Series Dual Valve Controller	Mechanical Dimensions	Process Connections ¹
All Standard Ranges	4.1"H x 4.8"W x 1.1"D	1/8" NPT Female

1. Compatible with Swagelok® tube, Parker®, face seal, push connect and compression adapter fittings.

Standard Available Ranges

PCD Series Pressure Controllers		
-15PSIG to 0PSIG		
2inH ₂ OD	2inH ₂ OG	
4inH ₂ OD	4inH ₂ OG	
1PSID	1PSIG	
5PSID	5PSIG	
15PSID	15PSIG	15PSIA
30PSID	30PSIG	30PSIA
100PSID	100PSIG	100PSIA
150PSID		300PSIA
Other ranges available. Please contact Alicat.		

Select One Unit of Measure when Ordering		
PSIA	inHG	Atm
PSIG	inH ₂ O	Torr
mmHG	mBar	kPa

P, PC and PC3 Dimensional Drawings

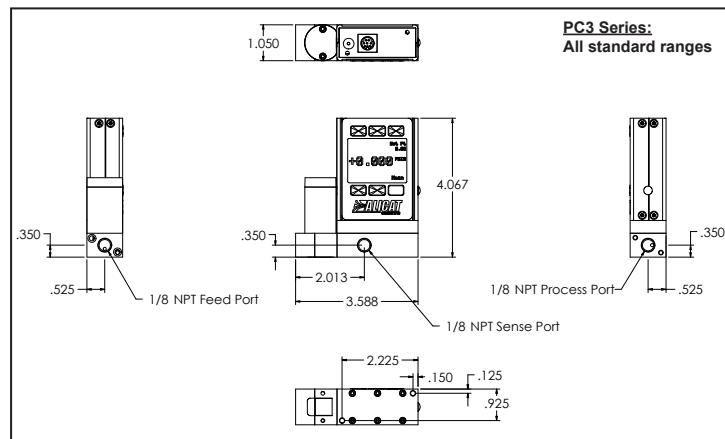
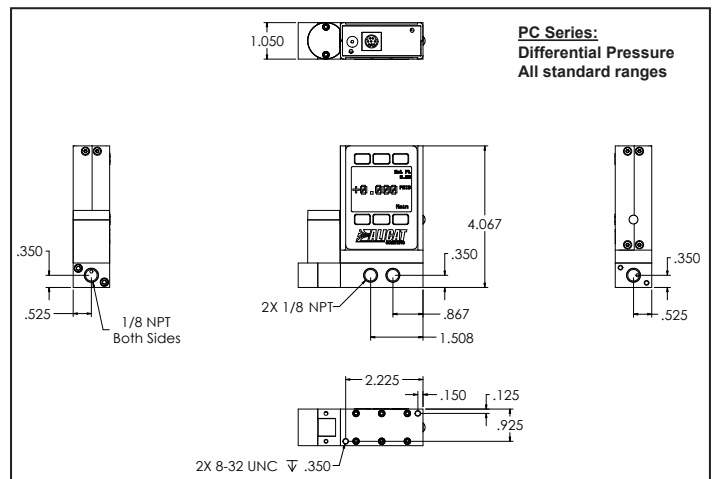
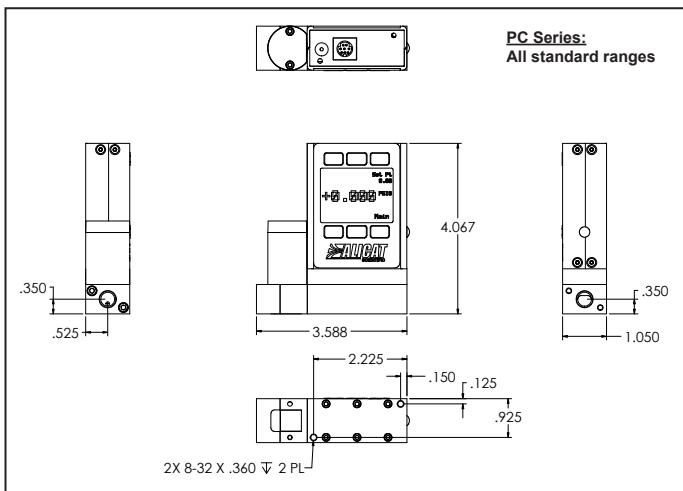
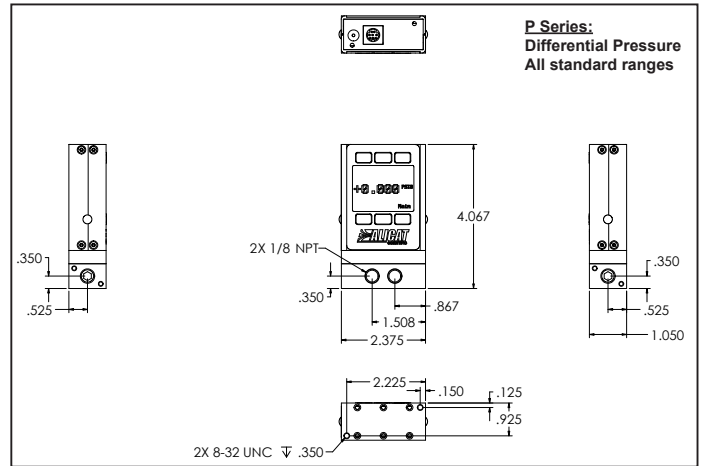
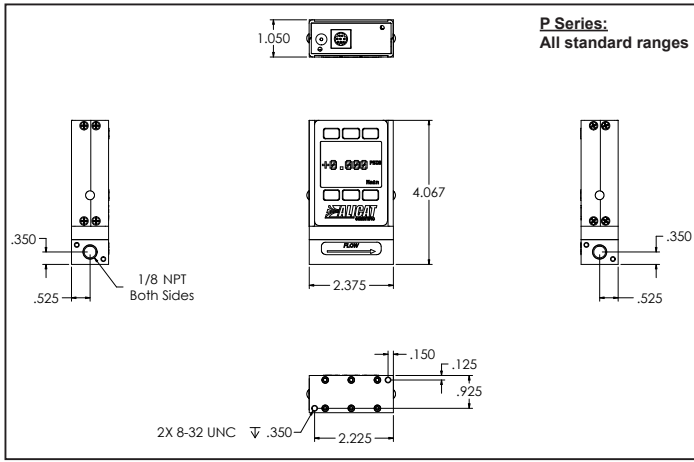

PCR, PCR3 and PCD Dimensional Drawings

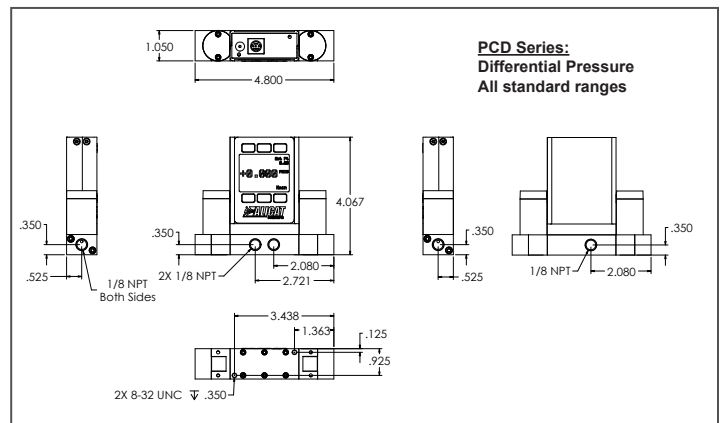
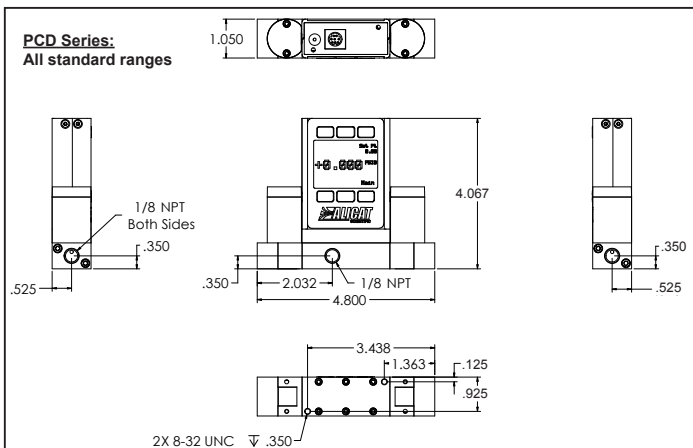
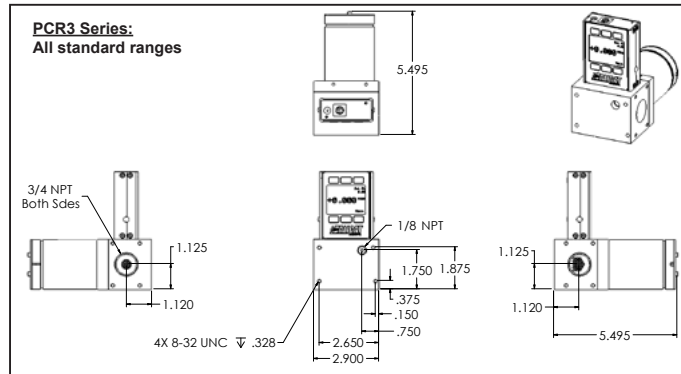
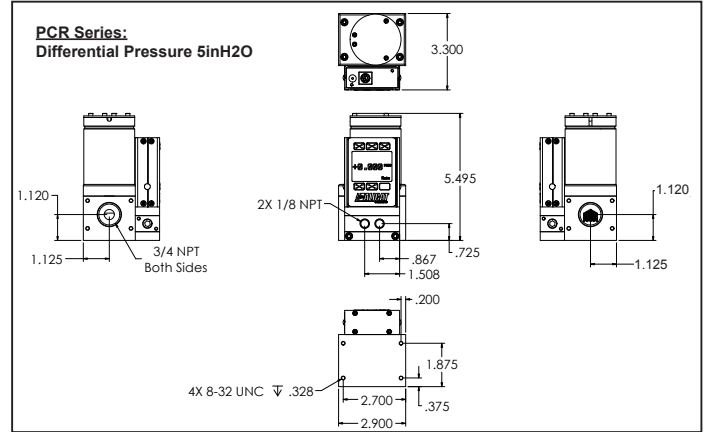
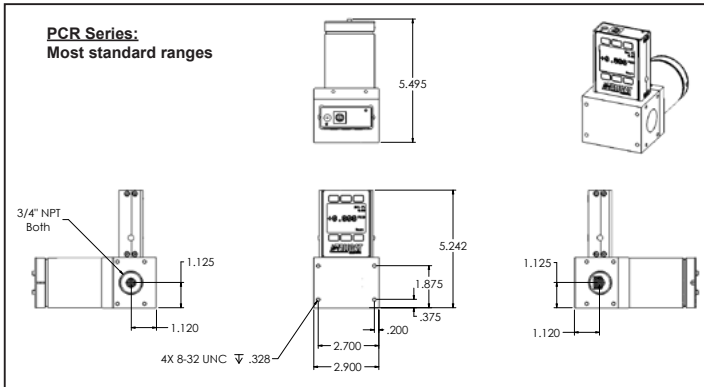

Technical Data for Alicat PS Series Pressure and Vacuum Gauges

Alicat PS instruments are built for use with aggressive gases. For the most part these instruments maintain the specifications of equivalently ranged P Series devices.

In addition to all non-corrosive gases, PS Gauges are configured to operate with the following aggressive gases.

PS Gauge Aggressive Gas Compatibility List :

NO	Nitric Oxide to 100%
NF3	Nitrogen Trifluoride to 100%
NH3	Ammonia to 100%
NO2	Nitrogen Dioxide to 100%
Cl2	Chlorine to 100%
H2S	Hydrogen Sulfide to 100%
SO2	Sulfur Dioxide to 100%
Propylene to 100%	

In addition the following gases are available upon request:

Refrigerant gases to 100% (refrigerant gases may require custom seals, consult Alicat)

If your application requires another gas or gas mixture, please contact Alicat. We will do our best to accommodate your request.

Technical Data for Alicat PCS, PCRS and PCDS Series Pressure and Vacuum Controllers

Alicat PCS, PCRS and PCDS instruments are built for use with aggressive gases. For the most part these instruments maintain the specifications of equivalently ranged PC, PCR and PCD Series devices.

In addition to all non-corrosive gases, PCS, PCRS and PCDS controllers are configured to operate with the following aggressive gases.

PCS, PCRS & PCDS Controller Aggressive Gas Compatibility List :

NO	Nitric Oxide to 100%
NF3	Nitrogen Trifluoride to 100%
NH3	Ammonia to 100%
NO2	Nitrogen Dioxide to 100%
H2S	Hydrogen Sulfide to 100% (22°C and under)
Propylene to 100%	

In addition, the following gases are available upon request:

Refrigerant gases to 100% (refrigerant gases may require custom seals, consult Alicat)

Other gases to 1000 ppm in an inert carrier

If your application requires another gas or gas mixture, please contact Alicat. We will do our best to accommodate your request.

Using PS, PCS, and PCRS Instruments with FLUIDS

PS, PCS and PCRS devices may be used with chemically compatible liquids. Please contact Alicat for technical assistance if your application involves fluids.

Technical Data for PS Pressure Gauges and PCS and PCRS Single Valve Pressure Controllers

The following specifications are for the standard configuration of the product. There are many low-cost customization options available. PCRS Series high flow pressure controllers are for applications with required flows above 20LPM. Please contact Alicat for additional PCRS operating specifications. Differential pressure ranges may be subject to extended lead times, please contact Alicat..

Operating Specifications

Specification	PS Series	PCS & PCRS Series	Description
Standard Accuracy	± 0.25%		Full Scale
High Accuracy Option	± 0.125%		Full Scale
Repeatability	± 0.08%		Full Scale
Turndown Ratio	200:1		
Adjustable Response Time ¹	5	100	Milliseconds
Operating Temperature	-10 to +50		Degree Celsius
Zero Shift	0.02%		Full Scale / °Celsius
Span Shift	0.02%		Full Scale / °Celsius
Excess Pressure	128% Measurable	102.4% Controllable	Full Scale
Burst Pressure	3X		Full Scale
Supply Current Peak	0.035	0.250 (PCRS: 0.750)	Amp
Supply Voltage	7 – 30	12 – 30 (PCRS Series = 24 – 30)	Volts dc
Input /Output Signal Standard	RS-232 or RS-485 Serial & 0-5Vdc or PROFIBUS or DeviceNet ²		
Electrical Connections	8 Pin Mini-DIN or DB-15		
Wetted Materials ³	316LSS, FFKM (Kalrez) standard; Viton, EPDM, Buna, Neoprene as needed for some gases. PCS, PCRS Series Controllers add: 303SS, 430FRSS		

1. Volumes, feed pressures, exhaust pressures and line sizing will determine the limits of response times.
2. If selecting PROFIBUS or DeviceNet no analog signal is available. PROFIBUS and DeviceNet units do not have the display. See PROFIBUS or DeviceNet specifications for supply voltages and supply currents.
3. If your application demands a different material, please contact Alicat for available options.

Mechanical Specifications

Pressure Product	Mechanical Dimensions	Process Connections ¹
PS Series Gauges ≤ 100PSIG	3.8"H x 2.4"W x 1.1"D	1/8" NPT Female
PS Series Gauges > 100PSIG	4.1"H x 2.4"W x 1.1"D	1/8" NPT Female
PCS Series Controllers ≤ 100PSIG	3.8"H x 3.6"W x 1.1"D	1/8" NPT Female
PCS Series Controllers > 100PSIG	4.1"H x 3.6"W x 1.1"D	1/8" NPT Female
PCRS Series Controllers	5.5"H x 2.9"W x 5.5"D	3/4" NPT Female

1. Compatible with Swagelok® tube, Parker®, face seal, push connect & compression adapter fittings. Alternates available.

Standard Available Ranges

PS Series Gauges			PCS, PCRS Series Controllers		
-15PSIG to 0PSIG			-15PSIG to 0PSIG		
1PSID	1PSIG		1PSID	1PSIG	
5PSID	5PSIG		5PSID	5PSIG	
15PSID	15PSIG	15PSIA	15PSID	15PSIG	15PSIA
30PSID	30PSIG	30PSIA	30PSID	30PSIG	30PSIA
100PSID	100PSIG	100PSIA	100PSID	100PSIG	100PSIA
150PSID		300PSIA	150PSID		300PSIA

Other ranges available. Please contact Alicat.

Select One Unit of Measure when Ordering		
PSIA	inHG	Atm
PSIG	inH ₂ O	Torr
mmHG	mBar	kPa

Technical Data for PCDS Dual Valve Pressure Controllers

The following specifications are for the standard configuration of the product. There are many low-cost customization options available. Differential pressure ranges may be subject to extended lead times, please contact Alicat.

Operating Specifications

Specification	PCDS Series	Description
Standard Accuracy	± 0.25%	Full Scale
High Accuracy Option	± 0.125%	Full Scale
Feed Valve Orifice	0.050 ¹	Inches
Exhaust Valve Orifice	0.050 ¹	Inches
Alternate Valve Orifices Available	0.010 or 0.030	Inches
Repeatability	± 0.08%	Full Scale
Turndown Ratio	200:1	
Adjustable Response Time ²	≤100	Milliseconds
Operating Temperature	-10 to +50	Degree Celsius
Zero Shift	0.02%	Full Scale / °Celsius
Span Shift	0.02%	Full Scale / °Celsius
Excess Pressure	102.4% Controllable	Full Scale
Burst Pressure	≥3X	Full Scale
Supply Current Peak	0.250	Amp
Supply Current Average	0.050	Amp
Supply Voltage	12 – 30	Volts dc
Input /Output Signal Standard	RS-232 or RS-485 Serial & 0-5Vdc or PROFIBUS or DeviceNet ³	
Electrical Connections	8 Pin Mini-DIN or DB-15	
Wetted Materials ⁴	316LSS, 303SS, 430FRSS, FFKM (Kalrez) standard; Viton, EPDM, Buna, Neoprene as needed for some gases.	

- Other sizes may be selected based upon process requirements
- Volumes, feed pressures, exhaust pressures and line sizing will determine the limits of response times.
- If selecting PROFIBUS or DeviceNet no analog signal is available. PROFIBUS and DeviceNet units do not have the display. See PROFIBUS or DeviceNet specifications for supply voltages and supply currents. Please contact Applications Assistance for PCD - PROFIBUS or DeviceNet options.
- If your application demands a different material, please contact Alicat for available options.

PCDS Series Dual Valve Controller	Mechanical Dimensions	Process Connections ¹
All Standard Ranges	4.1"H x 4.8"W x 1.1"D	1/8" NPT Female

1. Compatible with Swagelok® tube, Parker®, face seal, push connect and compression adapter fittings.

Standard Available Ranges

PCDS Series Pressure Controllers		
-15PSIG to 0PSIG		
1PSID	1PSIG	
5PSID	5PSIG	
15PSID	15PSIG	15PSIA
30PSID	30PSIG	30PSIA
100PSID	100PSIG	100PSIA
150PSID		300PSIA
Other ranges available. Please contact Alicat.		

Select One Unit of Measure when Ordering		
PSIA	inHG	Atm
PSIG	inH ₂ O	Torr
mmHG	mBar	kPa

PS, PCS, PCRS and PCDS Dimensional Drawings

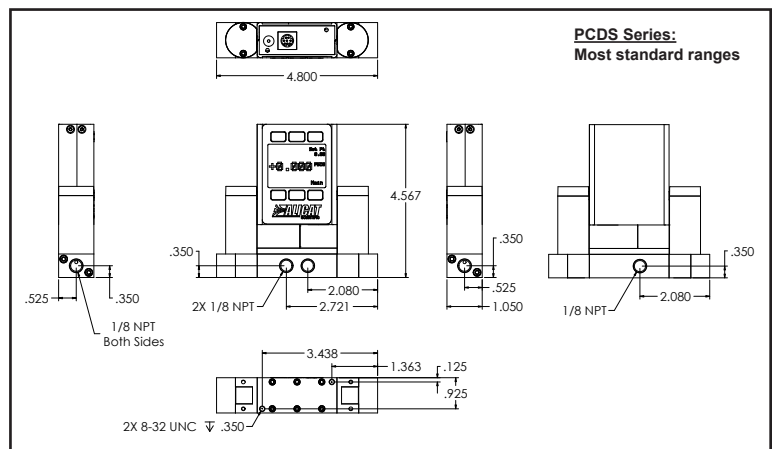
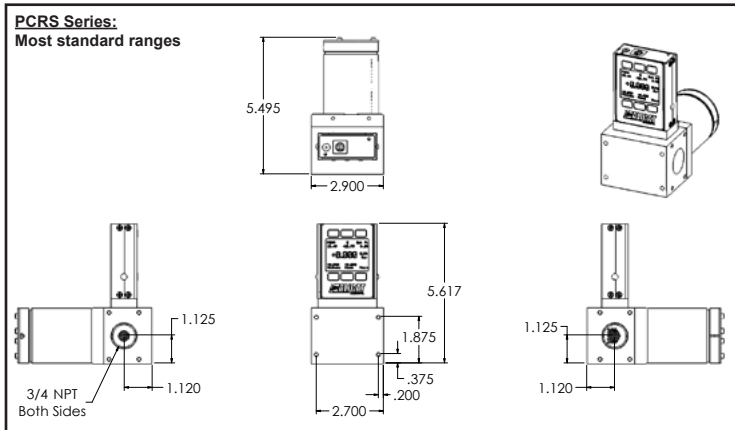
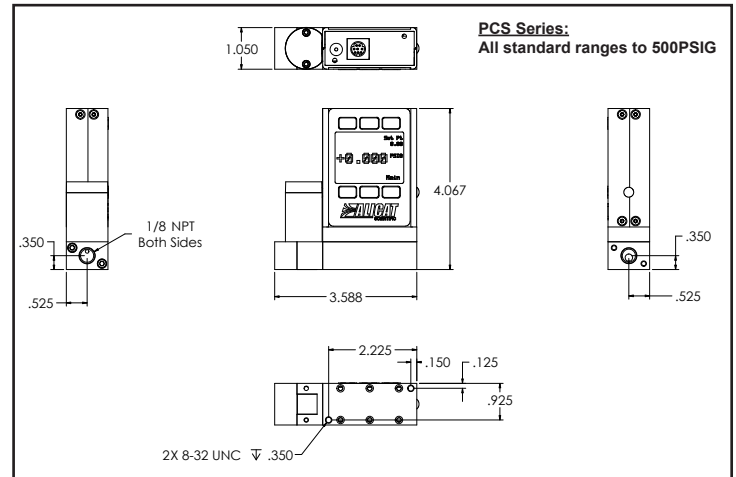
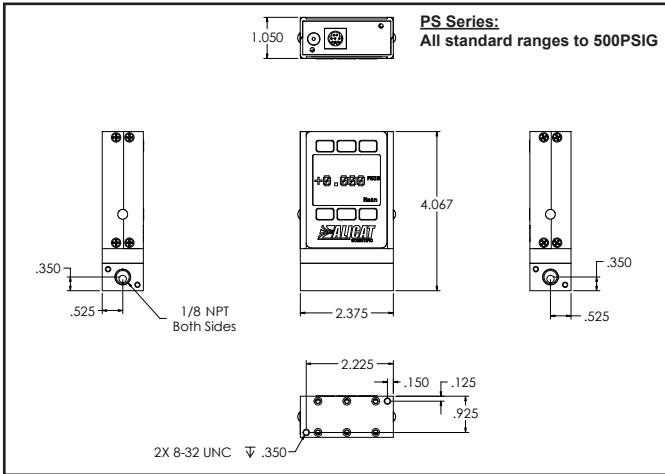

METERS and CONTROLLERS for WATER

Differential Pressure Laminar Flow Measurement

Alicat liquid meters and controllers operate on the same patented laminar differential pressure technology as found in all Alicat flow products.

In large scale industrial applications, differential pressure technology accounts for over 50% of liquid flow measurement. Now, Alicat allows you to benefit from this proven method of measurement in your very low flow water metering and control applications.

Alicat instruments measure differential pressure within a laminar flow region to determine volumetric flow rate. Flow is inherently linear in the laminar region so no linearization curve is required.

By measuring the temperature, viscosity of the water is calculated. Using differential pressure to determine velocity and knowing the viscosity, the internal microprocessor calculates the volumetric flow rate within $\pm 2.0\%$ of full scale.

Low Flow and High Turndown with Laminar Technology

Alicat **L** series meters can measure flow rates as low as 0.5CCM full scale through flow rates as high as 10LPM full scale with a turndown ratio of 50:1 and $\pm 2\%$ of full scale accuracy.

LC series controllers will control liquid flows from 5CCM full scale through 500CCM full scale with a turndown ratio of 50:1 while still maintaining an accuracy of $\pm 2.0\%$ full scale.

The **LCR** is the high flow controller with a range of 1LPM to 5LPM and utilizes Alicat's LRV control valve designed for high flow and low pressure drop.

Both meters and controllers are equipped with bleed ports so that air may be easily removed.

No special plumbing, straight runs of pipe or reference charts are required to operate the Alicat meters and controllers.

Multiple Parameter Measurement

Read both *water flow and water temperature* — in one compact device.

An optional discrete pressure sensor will allow you to read *water pressure* as well.

No Warm-Up Time!

In less than one second after power up, you are ready to begin accurate measurement and control of your process.



LCR Series



LC Series



L Series

Also Available:

Alicat's Portable Liquid Meter Kit for High Performance Liquid Chromatography Flow Calibration. Call for details.

Pressure Gauges and Pressure Controllers for Water

Alicat **P** and **PC** series pressure instruments are perfect for many water pressure applications. Please contact our engineers for details.

Technical Data for Water Flow L Meters & LC & LCR Water Flow Controllers

Specification	L Series	LC Series	LCR Series	Description
Available Ranges	0.5CCM to 10LPM	5CCM to 500CCM	1LPM to 5LPM	Full Scale
Accuracy	± 2 %			Full Scale
Repeatability	± 2 %			Full Scale
Operating Range	2% to 100% Full Scale			Measure or Control
Typical Response Time	20	100		Milliseconds (Adjustable)
Operating Temperature	+10 to + 50			°Celsius
Zero Shift	0.02%			Full Scale / °Celsius / Atm
Span Shift	0.02%			Full Scale / °Celsius / Atm
Flow Rate	128% Measurable	102.4% Controllable		Full Scale
Common Mode Pressure	100			PSIG
Supply Current	0.040	0.250	0.750	Amp
Supply Voltage	7—30 ²	12—30 ²	24-30	Vdc
Input /Output Signal Digital	Temperature and Flow (Optional pressure sensor available)			RS-232 Serial or RS-485 Serial or PROFIBUS or DeviceNet ¹
Input /Output Signal Analog	Volumetric Flow			0-5Vdc
Optional Input / Output Signal Secondary Analog	Pressure, Temperature or Flow			0-5 Vdc; 0-10Vdc;4-20mA ²
Electrical Connections	8 Pin Mini-DIN or DB-15			
Mounting Attitude Sensitivity	None	Control response somewhat sensitive to inverted operation.		Tare after installation
Wetted Materials ³	303 & 302 Stainless Steel, Viton®, Silicone RTV (Rubber), Polyetherimide, Silicon, Glass. LC Controllers Add: 430FR Stainless Steel, Brass. LCR Controllers Add 416 Stainless Steel, Delrin®.			
<p>1. If selecting PROFIBUS or DeviceNet no analog signal is available. PROFIBUS / DeviceNet units do not have the display. See PROFIBUS or DeviceNet specifications for PROFIBUS or DeviceNet supply voltages and currents.</p> <p>2. 15 volts required for 4-20mA output.</p> <p>3. If your application demands a different material, please contact Alicat for available options.</p>				

Full Scale Flow	Mechanical Dimensions	Process Connections ¹	Pressure Drop ² (PSID)
L Series			
0.5CCM to 1CCM	4.4"H x 2.4"W x 1.1"D	M5 (10-32) Female Thread*	2.0
2CCM to 500CCM	4.6"H x 2.4"W x 1.1"D	1/8" NPT Female	2.0
1LPM			4.0
2LPM			4.0
5LPM			10.0
10LPM	5.1"H x 4.0"W x 1.6"D	1/4" NPT Female	20.0
LC Series			
5CCM to 50CCM	4.6"H x 3.6"W x 1.1"D	1/8" NPT Female	5.0
100CCM			5.0
200CCM to 500CCM			7.5
LCR Series			
1LPM	5.7"H x 7.7"W x 2.3"D	1/4"NPT Female	4.0
2LPM			4.0
5LPM			10.0

*Units ≤1CCM F.S. are shipped with M5 (10-32) Male Buna-N O-ring face seal to 1/8" Female NPT fittings. These adaptor fittings were selected for customer convenience in process connection. It should be noted that the 1/8" Female NPT introduces additional dead volume. To minimize dead volume, please see [Accessories](#) for the M5 (10-32) Male to 1/8"OD compression fitting.

- Compatible with Beswick®, Swagelok® tube, Parker®, face seal, push connect and compression adapter fittings.
- Lower Pressure Drops Available, Please contact Alicat.

L Series Dimensional Drawings

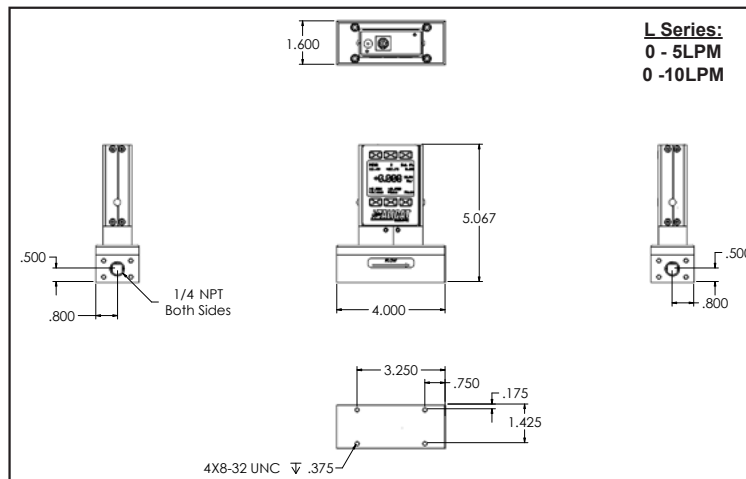
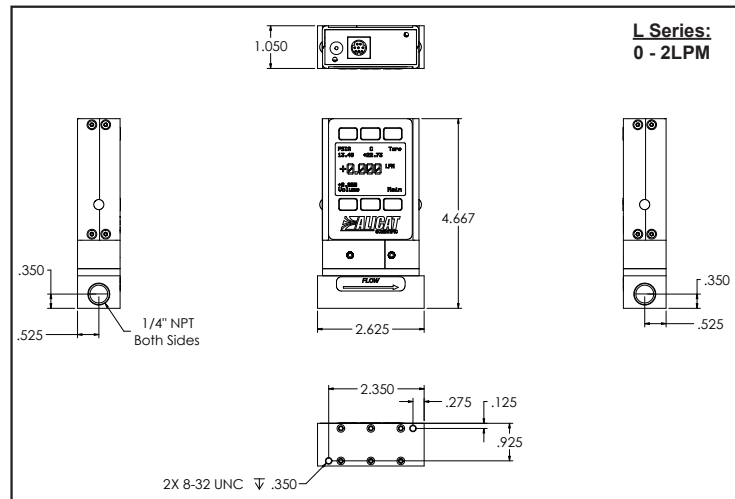
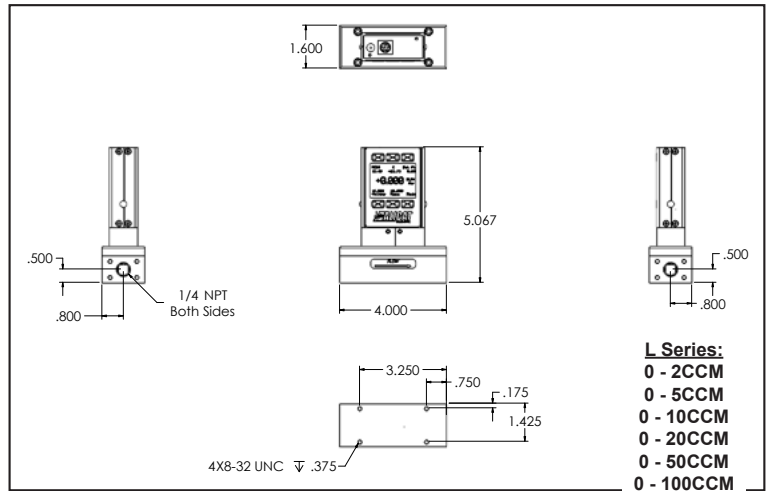
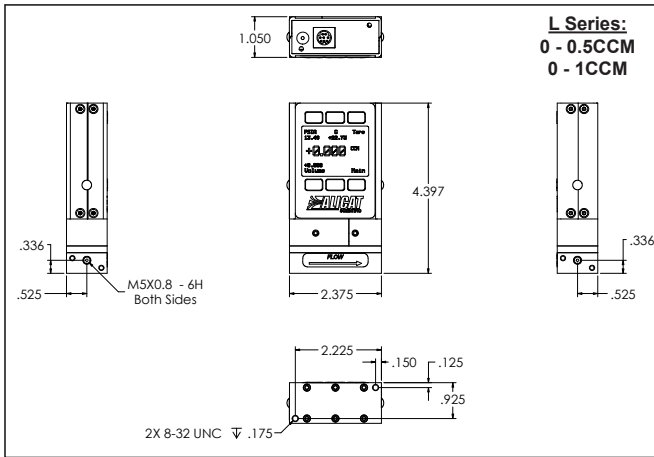

LC and LCR Series Dimensional Drawings

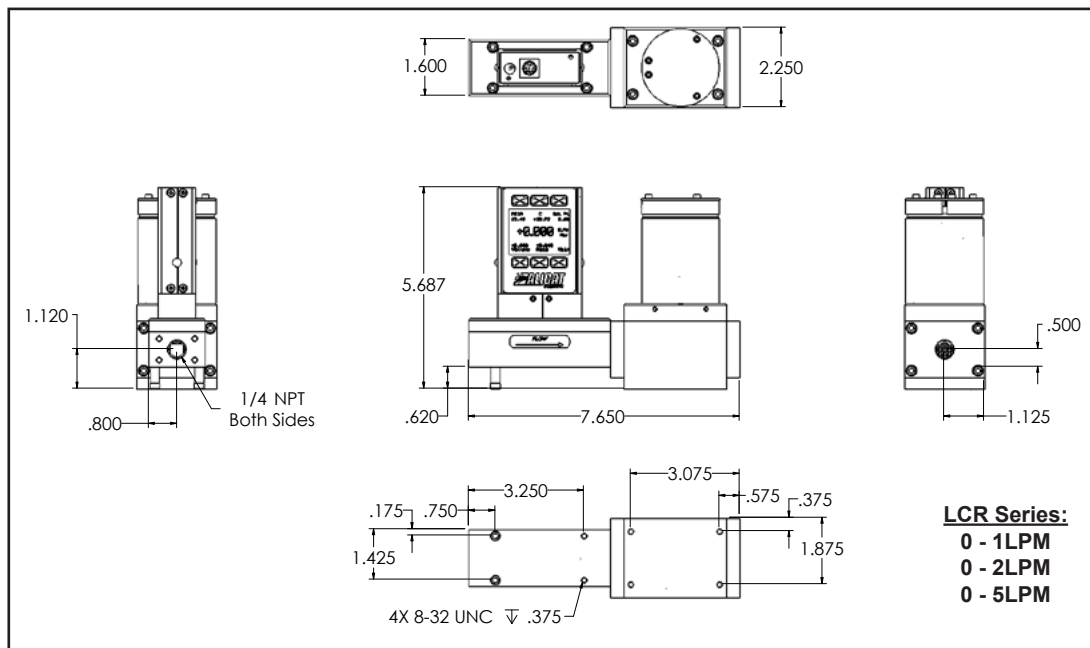
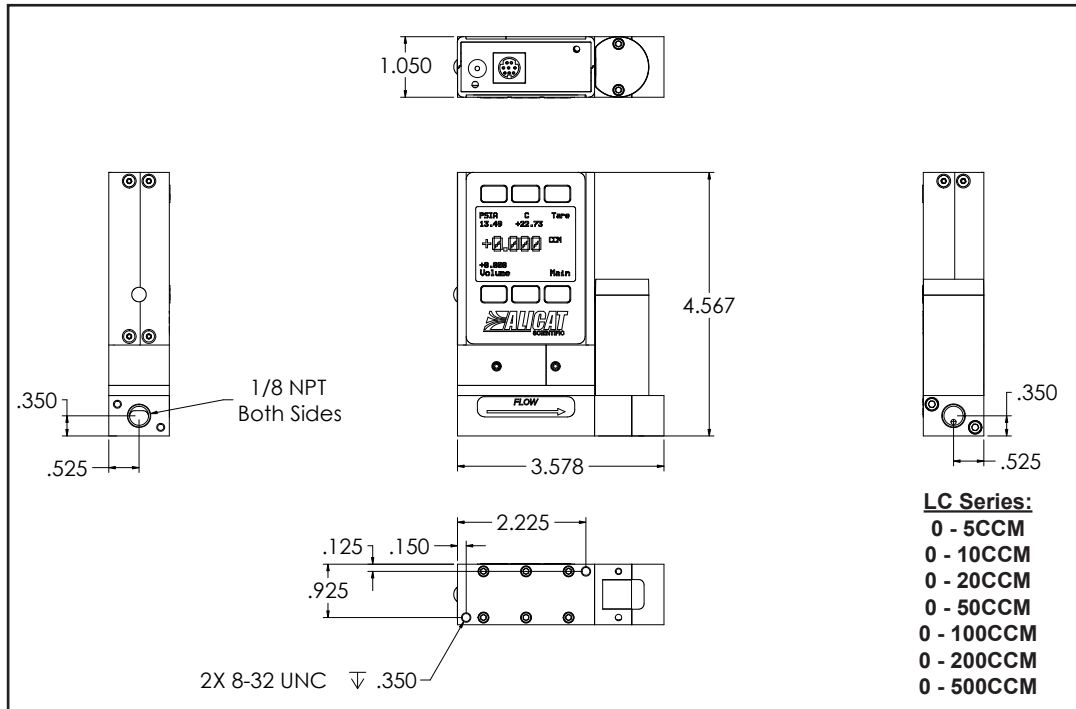

OPTIONS, ACCESSORIES, SUPPORT

- At Alicat, we will work with you to solve your flow management problems.
- Our engineers are always accessible and pride themselves in finding innovative ways to meet your flow application needs.
- Whether for research or OEM, our instrumentation can usually be configured or customized to meet your specific requirements.
- Although our instruments are unequalled in stand-alone functionality, Alicat offers a wide range of options and accessories.

MORE COMMUNICATION OPTIONS

You can now order any Alicat instrument with RS-232, RS-485, PROFIBUS DP-V1 or DeviceNet compatible communications!



ATEX & CSA CLASS 1 DIVISION 2

Alicat has attained ATEX and CSA approval for the use of Alicat Mass Flow Meters, Mass Flow Controllers and Pressure Equipment in Class 1 Division 2 hazardous environments for Canada and the United States and Class 1 Zone 2 for Europe.



TFT LCD COLOR DISPLAY OPTION

- ▶ Hi-Contrast, Backlit Multi-Color TFT LCD
- ▶ Increased Baud Rates Available (up to 115200)
- ▶ 125% Faster Processor Speed
- ▶ PID Algorithm Selection: pdf or pd2i



DB15 Connector

The DB15 style electrical connector is available as an alternative to Alicat's standard 8-pin mini-din connection or optional 6-pin locking industrial connection.

The DB15 pin-outs can be configured to easily integrate with many existing 15-pin cabling set-ups.



Lifetime Warranty!

And Technical Support with every Alicat Instrument

Whether your application calls for precision, speed or flexibility, let Alicat make your job easier.

- ▶ You'll get quick delivery with outstanding standard features and a wide choice of options.
- ▶ Our engineers have what it takes to ensure you are getting the most from your device and more importantly your application.
- ▶ Our service department provides low cost recalibrations and quick turnaround.

Call (888) 290-6060 or visit our web site to learn more about Alicat's unique line of flow and pressure products.

REMOTE DISPLAY

Our Remote Display (RD) option offers the flexibility of using Alicat's display with units that are embedded inside processes.

The RD retains all of the same features as our standard display. TFT color remote display option shown at right.

Our digital display allows you to monitor flow, temperature and pressure data in real time. Depending on the device, the display also permits you to easily select a gas, control set-point or activate tare.

The Remote Display is ideal for:

- ▶ OEMs Remote Panel mounting
- ▶ Gas panels
- ▶ Leak detection systems
- ▶ Embedded systems
- ▶ Fuel cell test stations
- ▶ Artificial environments



REMOTE ELECTRONICS for High Temperature Applications

Some applications involve ambient and operating temperatures outside the standard Alicat device specifications. Our Remote Electronics option addresses this dilemma.

Relocating the electronics allows for installation of the flow body in ambient temperatures as high as 85° Celsius with gas temperatures up to 100° Celsius.

Remote Electronics can also be useful in applications that require the installation of a compact flow package.

NeSSI COMPATIBLE

Alicat Scientific is a proud participant in **NeSSI (New Sampling/Sensor Initiative)**.

Many Alicat instruments are now available in a **NeSSI** compatible design.

If your application calls for a **NeSSI** device, please let us know. We are committed to providing superior instruments that will meet your requirements.



WELDED FITTINGS

For applications in which cleanliness of the gas stream is paramount, Alicat offers welded VCR® and VCO® style fittings.

VCR® and VCO® fittings are commonly used in vacuum and low pressure processes.

Welded fittings are available on almost all Alicat products and can be ordered in a variety of configurations.

IPC (Integrated Potentiometer Control)

The IPC option is an easy way to adjust the set-point of any Alicat controller.

The single turn potentiometer allows the operator to select a control set-point without an external control input signal.

Simply plug in the power supply, attach your gas flow lines and you're ready to accurately control your flow.



Please visit our web site or call Alicat for additional customization options, including:

Gas Mixtures, Totalizer, Customized Pressure Drops, Bi-Directional Flow Readings, Alarms, Alternate Units of Measure and more!

ACCESSORIES

BB9 Multi-Drop Box

The **BB9 Multi-Drop Box** makes it convenient to wire multiple flow and/or pressure devices to a single RS-232 / RS-485 port. **Now available with a USB interface!**

The Multi-Drop Box has nine 8 pin mini-DIN ports available. The ports are to be used with a standard double ended 8 pin mini-DIN (DC-62) style cable going from the box to each flow or pressure device.

A single DB9 D-SUB type connector (COM PORT) connects, using the included cable, to the serial connector on a PC or laptop.

All of the flow and/or pressure devices may be powered via a terminal block on the front of the box.

If more than nine devices will be required, additional Multi-Drop Boxes can be daisy chained together with a double ended 8 pin mini-DIN cable plugged into any receptacle on both boxes.

BB9 Power Supply for Large Valve Controllers: The PS24VHC (Power Supply 24Vdc High Current) is a 6.5Amp 24Vdc power supply designed for running multiple large controllers on a BB9.

The 6.5Amp power supply can run as many as 8 large valve controllers, which makes it ideal for the BB9 and multiple large valve (or small valve / large valve combination) controllers on a BB9.

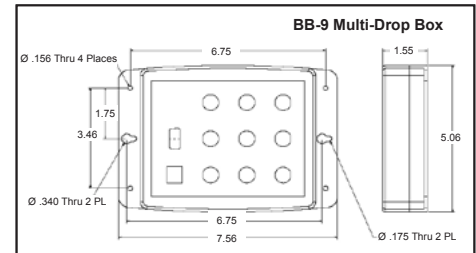

Power Supply

Power supplies are typically ordered to facilitate "out of box" use of Alicat devices when it is inconvenient or impossible to provide DC power to a device through the electrical connector.

VPVS24U: This universal power adapter accepts 100 to 240 VAC 50/60 Hz power and changes it to a regulated 24 Vdc capable of producing 1000mA. The adapter includes five interchangeable AC plugs for convenient use world-wide.

Fittings, Filters, Adapters

We carry a full line of Swagelok® compression fittings in 316 stainless steel. Other fittings and filters are available upon request.

MNPT to Compression Fittings	
10-32 - 1/8"	SS-200-1-0157
10-32 - 1/4"	SS-400-1-0256
1/8" - 1/8"	SS-200-1-2
1/8" - 1/4"	SS-400-1-2
1/8" - 3/8"	SS-600-1-2
1/8" - 1/2"	SS-810-1-2
1/8" - 3mm	SS-3M0-1-2
1/8" - 4mm	SS-4M0-1-2
1/8" - 6mm	SS-6M0-1-2
1/8" - 8mm	SS-8M0-1-2
1/8" - 12mm	SS-12M0-1-2
1/4" - 1/8"	SS-200-1-4
1/4" - 1/4"	SS-400-1-4
1/4" - 3/8"	SS-600-1-4
1/4" - 1/2"	SS-810-1-4
1/4" - 3mm	SS-3M0-1-4
1/4" - 4mm	SS-4M0-1-4
1/4" - 6mm	SS-6M0-1-4
1/4" - 8mm	SS-8M0-1-4

MNPT to Compression Fittings	
1/4" - 12mm	SS-12M0-1-4
1/2" - 1/8"	SS-200-1-8
1/2" - 1/4"	SS-400-1-8
1/2" - 3/8"	SS-600-1-8
1/2" - 1/2"	SS-810-1-8
1/2" - 3/4"	SS-1210-1-8
1/2" - 6mm	SS-6M0-1-8
1/2" - 8mm	SS-8M0-1-8
1/2" - 12mm	SS-12M0-1-8
1/2" - 16mm	SS-16M0-1-8
3/4" - 1/4"	SS-400-1-12
3/4" - 1/2"	SS-810-1-12
3/4" - 3/4"	SS-1210-1-12
3/4" - 12mm	SS-12M0-1-12
3/4" - 16mm	SS-16M0-1-12

Filters & Elements FNPT-MNPT	
10-32 5µ	510053
10-32 20µ	510054
1/8" 20µ	ILF-1/8-20
1/4" 40µ	ILF-1/4-40
1/2" 40µ	ILF-1/2-40*
3/4" 40µ	ILF-3/4-40*
20µ element	ILFE20
40µ element	ILFE40
40µ element	ILFE40L*

Filters & Elements FNPT-FNPT*	
10-32 5µ	CF-303-20-316

*requires MNPT to MNPT coupler to interface with Alicat flow bodies

10-32 Male UNF to 1/8 FNPT Adapter	
410133	
Male M5 (10-32) Buna-N O-ring face seal to 1/8"Female NPT	

*Our micro-flow devices (i.e. gases ≤50SCCM full scale and water ≤1CCM full scale) utilize an M5 (10-32) thread female process connection. This connection was chosen to provide a thread that is compatible with miniature process fittings.

Connecting Cables - Recommended Accessory

The electrical connector on most Alicat units is female. A male connecting cable can be ordered: to provide power to the unit from a customer supplied DC voltage source; to access output and input signals in communication; or to activate remote tare.



DC-61: 8-pin circular mini-din connector cable, 6' long with one male connector. The opposite end is blunt cut with color-coded wires.
DC-251 =25'; **DC-501**=50';
DC-751=75'; **DC-1001**=100'



MD8DB9: Male 8-pin circular din to female DB9 adapter cable, 6' long, typically used to simplify connection direct to a PC.
It will not pass power to the unit.



DC-62: Double-ended male 8-pin circular mini-din connector cable in 6' length. It is a straight pin-to-pin cable.
DC-252 =25'; **DC-502**=50'



DBC-251: Cable - Single Ended DB15 Female, 25'



DC-6RT: Lower profile alternative. This is a right angle, 8-pin circular mini-din connector cable at 6' long with one male connector. The opposite end is blunt cut with color-coded wires.



510368: Cable - Female DB15 to Female DB15, 15'



IC-10: 6-pin industrial style locking cable, 10' long with one male connector. Opposite end is blunt cut with color-coded wires. This cable reduces the number of optional signal configurations.
IC-20 = 20'; **IC-50** = 50'



DB9MDB9F: Cable Null Modem DB9M to DB9F 3 meters long



IC-102: 6-pin industrial style locking cable, 10' long with two male connectors.



510199: Cable - Female DB9 to Female DB9, 3 meters long

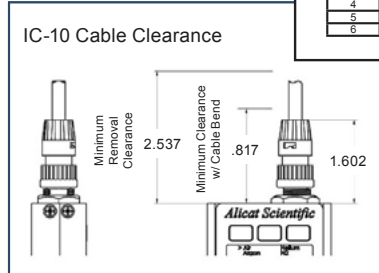
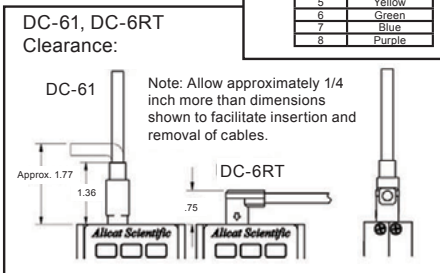
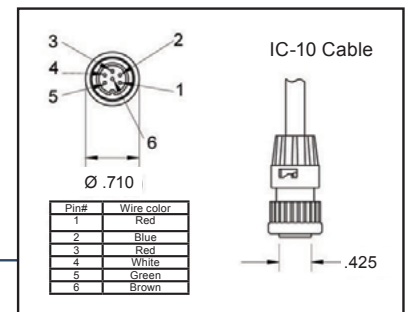
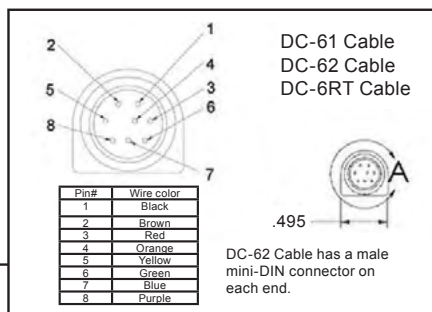

Sputtering Flow Control

In the process of sputtering, a plasma gas (typically argon) is used to fill a vacuum chamber which contains a target lattice and a substrate. The amount of plasma gas within the chamber is critical to control of the number of atoms released from the target lattice.

In reactive sputtering, reactive gasses like oxygen and nitrogen are added to the chamber (usually for coating substrates with compound atoms like titanium oxide).

Proper partial pressures of reactive gasses must be maintained within the chamber to prevent target poisoning.

Fast response times and fine flow resolution are crucial to this application.

For longer cathode arrays and sputtering applications using multiple gas sources, multiple mass flow controllers can be controlled from one serial connection or through analog input/output.

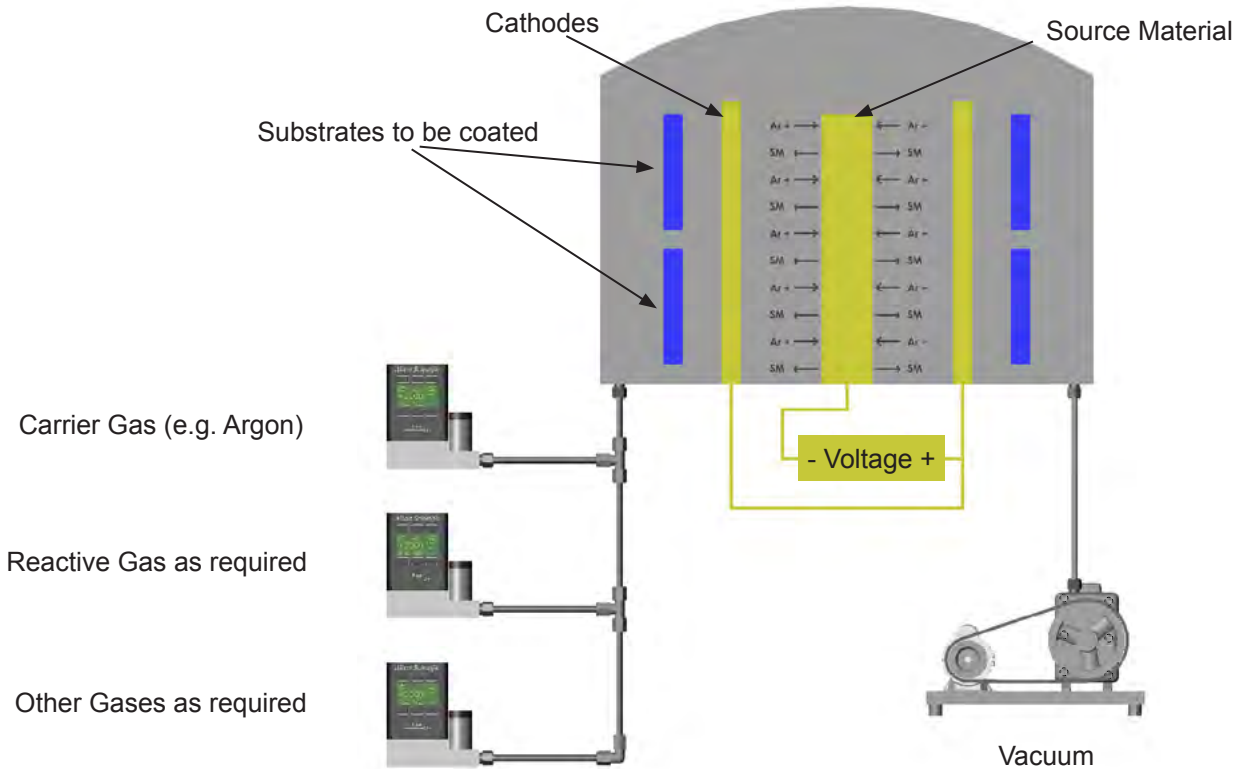

Alicat Advantages:

- ▶ Relative Insensitivity to Process & Ambient Temperature and Pressures Changes.
- ▶ Downstream Valves provide full compatibility with High Vacuum Process Chambers.
- ▶ 25-100 millisecond control times. ▶ Tune the PID in the field for your specific application.
- ▶ Selectable Loop controls allow you to control Mass Flow, Volumetric flow, or Absolute Pressure with the same device, while simultaneously measuring Mass Flow, Temperature, Volumetric Flow, and Absolute Pressure.
- ▶ Multi-Drop RS-232 communications allows communication and set-point control with up to 26 Alicat devices from a single computer serial port.
- ▶ Gas Select™ field selectability for more than 30 of the most common gases and blends

External Ion Gauge Vacuum Control System

The external ion gauge vacuum control system uses a special configuration of the Alicat single valve pressure controller. Alicat's **External Ion Gauge Vacuum Controller** was designed specifically for the vacuum coating industry.

This innovation circumvents the low end range of our pressure sensors and allows for control of extreme vacuum conditions in the coating chamber.

The controller provides lightning fast control based on data provided by an ion gauge vacuum sensor with a linear 0-10 volt output of pressure. The controller translates the signal and precisely controls extreme vacuum pressures within the process chamber.

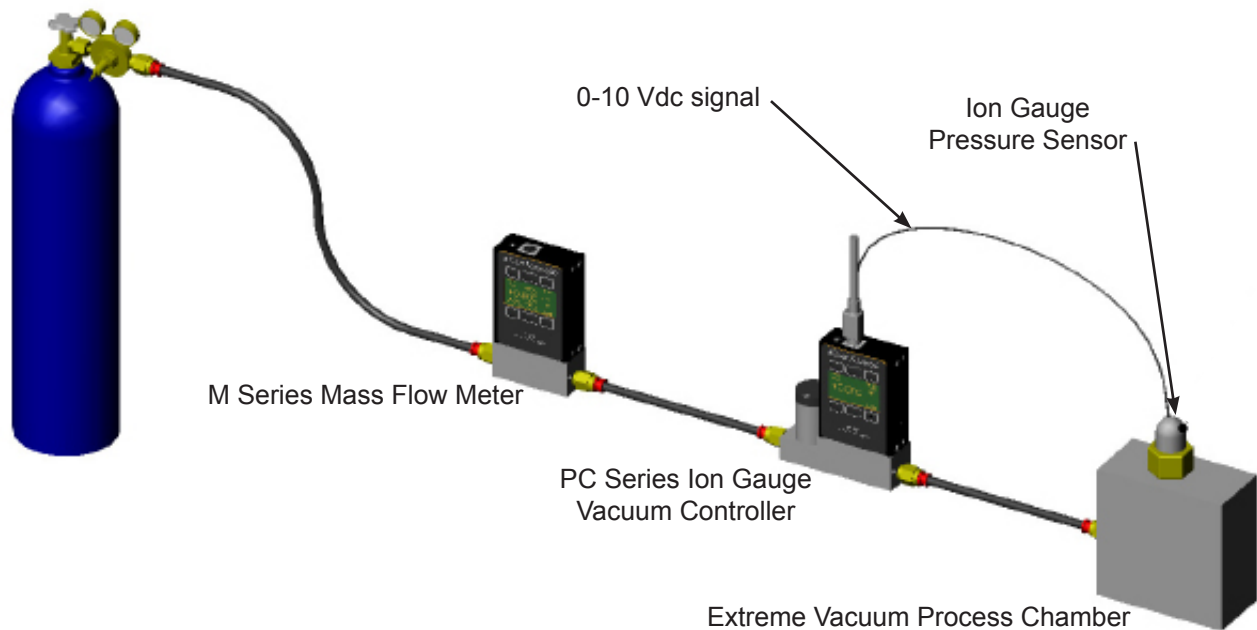

In this application, the 0-10V signal correlates to 0-0.5 Torr. The controller utilizes the pressure signal from the ion gauge to precisely control extreme vacuum conditions in the coating chamber.

The mass flow meter upstream of the pressure controller is unaffected by the vacuum conditions and measures precise mass flow, volumetric flow and the totalized mass of gas into the chamber.

Set-points can be delivered to the controller locally with an analog signal or via the RS-232 serial connection.

Please contact a sales engineer to discuss your external ion gauge system application.

Alicat Controllers in SOFC Applications

Traditional fuel cell stacks are dependent upon mass flow control devices to regulate the flow of fuel gas into the reformer (in the case of hydrocarbon fueled systems) or hydrogen and air or oxygen directly into the stack (in the case of hydrogen fueled systems). SOFC stacks have the additional requirement of preheating prior to the start of power generation. Controlling the rate of temperature rise is a critical factor in preventing damage to the fuel cell stack during the transition from room temperature to operating temperature.

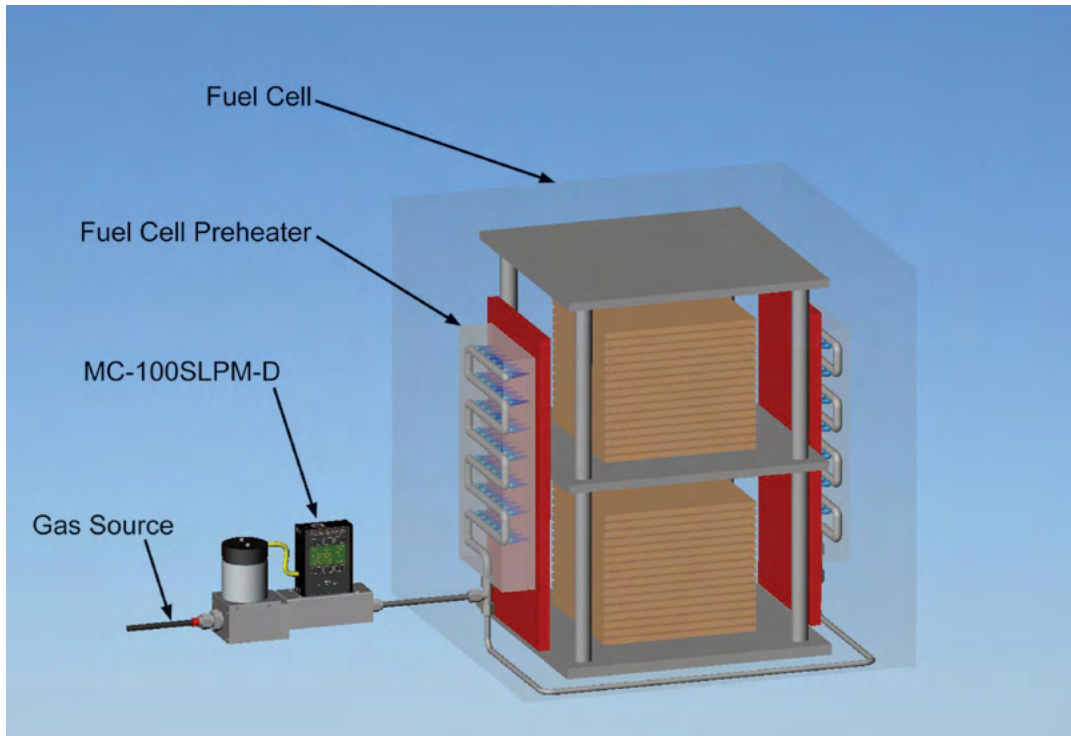

Much of the time, catastrophic damage to fuel cell stacks is caused by malfunctions in the ancillary equipment. SOFC stacks are particularly vulnerable to cracking induced by uneven heating or too high a heating rate during startup. Alicat Scientific mass flow controllers provide the very fast, very precise control needed to protect SOFC stacks from thermal transient damage during the startup cycle.

When driven by RS-232 set-point signals, Alicat controllers can be incremented by as little as 1/64,000 of full scale flow. This allows minute adjustments to be made in the amount of fuel burned per unit time. By monitoring the stack temperature directly, the customer's control computer can keep the temperature vs. time profile smooth and on track.

The very high bandwidth inherent in all Alicat controllers, allows them to quickly respond to transients in fuel gas supply pressure. Alicat mass flow controllers read the flow and correct the drive to the control valve about 1000 times per second. In that manner, fuel pressure transients (such as one might experience when the reformer is being initially charged) are quickly compensated for. Typical response to step changes in flow are faster than 50 milliseconds.

Fuel Cell Testing

This system is used to increase reliability, repeatability and speed of leak tests on Solid Oxide Fuel Cell (SOFC) membranes. The test is performed with helium gas.

The dual valve pressure controller (PCD) replaces the manual pressure regulator. With the automatic adjustments for line pressure changes, the PCD introduced precise pressure control that is highly repeatable between facilities.

The micro flow mass flow meter (MFM) was installed in place of a bubble meter. Using a MFM allows for automatic compensation for density effects due to line pressure and temperature changes which isn't possible with bubble meters. The fast 10ms response also allows for significant time savings over the bubble meter system for determining and isolating leak size.

Data communication for the PCD and MFM with a single PC allows for easy automation. This customer uses intuitive Flow Vision[™] SC software to design automated set-point tests and to automatically store the test data for reference.

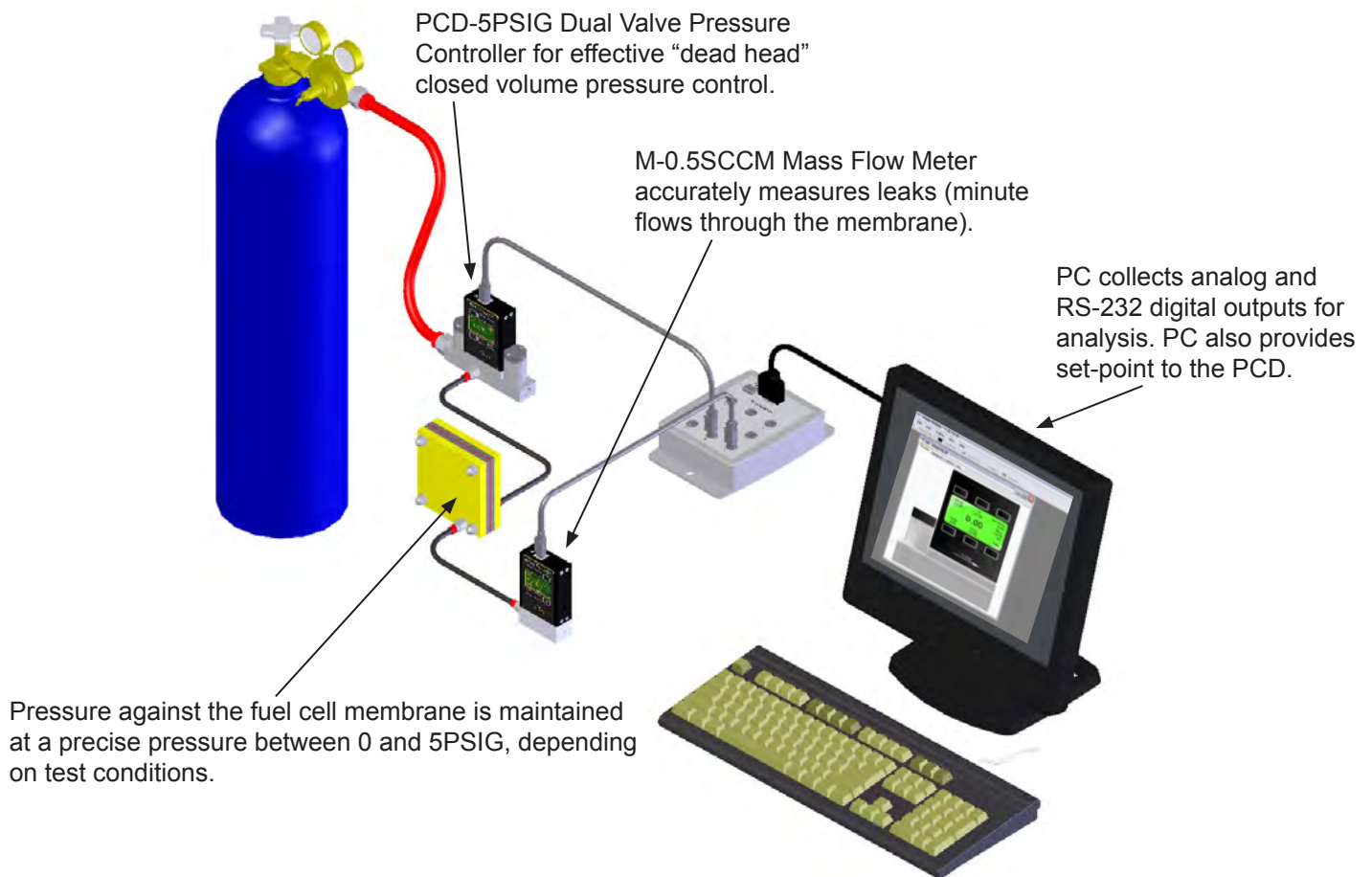

Faster Leak Checking

Many processes require a fast, accurate and reliable method for leak checking components. This can be accomplished by utilizing an Alicat Scientific M Series mass flow meter sized appropriately for the expected leak rate and an Alicat Scientific PC3 Series remote sensing pressure controller sized for the required pressure.

Alicat Scientific M Series mass flow meters are available with full scale ranges as small 0.5 SCCM with true 200:1 turndown ratio, meaning that flows as low as 2.5 microliters (0.0025 SCCM) can be resolved.

If plumbed as shown in the diagram, the pressure is controlled at the entrance to the Device Under Test (DUT). A constant bleed through the needle valve allows the pressure controller to precisely hold the pressure at the DUT, ensuring that any flow through the meter after the bypass valve is closed is due either to leakage or to a cooling of the volume of the DUT.

Providing the temperature of the DUT is constant, the flow reported at the meter will be the leak rate of the DUT. Reducing dead volume between the flow meter and the DUT and the volume of the DUT itself will reduce the effects of temperature change and make the leak checking process faster.

Note: This process may not be suitable for leak tests on larger volumes where the allowable leakage is near zero because minute temperature differences on large volumes can produce actual flows that are greater than the allowed leakage rate. This same problem of physics would also affect leak checking by pressure decay.

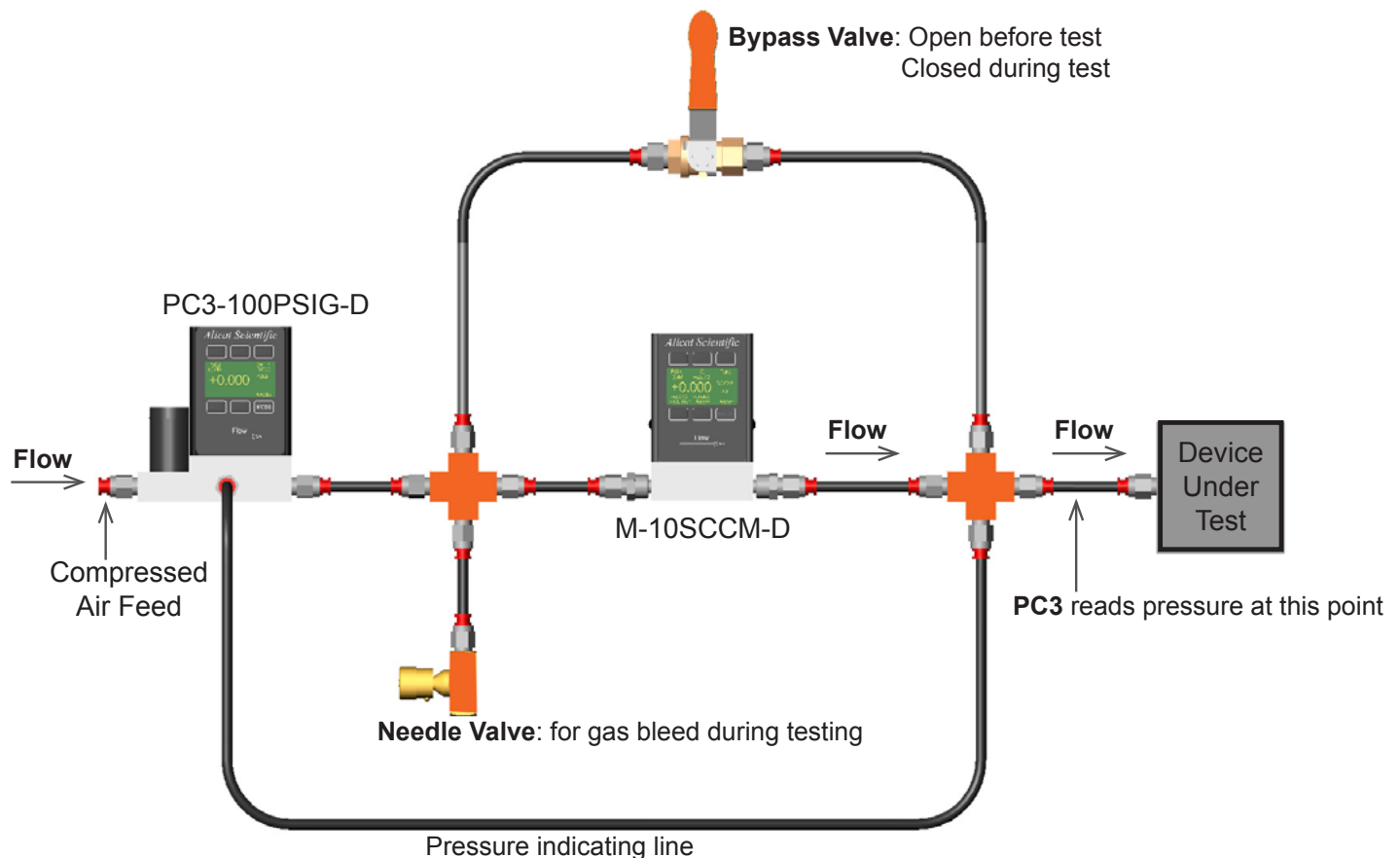

In-House Check of Gas Chromatograph Operation

Gas chromatographs (GCs) detect materials at molecular level by preparing a sample of the material that is “carried” on a gas stream into the GC. The carrier gas flow stream is sent into small capillary flow tubes and then into detectors to sense and quantify the suspected materials.

These carrier and capillary flow rates are critical to the correct performance of the gas chromatograph. The flow rates and pressures through the various gas flow paths vary by manufacturer’s specifications.

Alicat Scientific has recognized the need for an accurate and versatile device that is capable of verifying these critical aspects of a GC’s performance. The Alicat portable mass flow meter performs multiple tasks:

- Verification of mass measurement on the input and vent of the GC
- Verification of volumetric measurement on the vent of the GC
- Verification of the pressure on the inlet and vent of the GC

You will also benefit from:

- **Gas Select™** field selectability for 30 of the most common gases
- \pm (0.8% of Reading + 0.2% of Full Scale) Accuracy for precise measurements
- \pm 0.2% Full Scale Repeatability for consistent measurements
- 10mS or faster response to changes in flow, pressure and temperature
- 200:1 Turndown Ratio allows one unit to cover both the capillary and carrier gas flow ranges
- RS-232 Serial Output of all four parameters and selected gas for data logging to any PC, PDA or other device with serial terminal capability.

These multiple features, built into one, compact, portable instrument, give you an invaluable tool for the verification of GC operation.



Alicat Portable MB-20SCCM-TFT

Flame and Burner Monitoring

The flow meter is used to measure the flow of fuels such as Propane, Butane, Acetylene, or Methane (Natural Gas) to a burner or flame head. Oxygen or Air flow can also be easily measured in the same device. Mass flow measurements are used to determine and regulate the theoretical energy content of the flame, and the combination of the flow and pressure measurements are useful for diagnosing system leaks or blockages on the burner orifice(s).

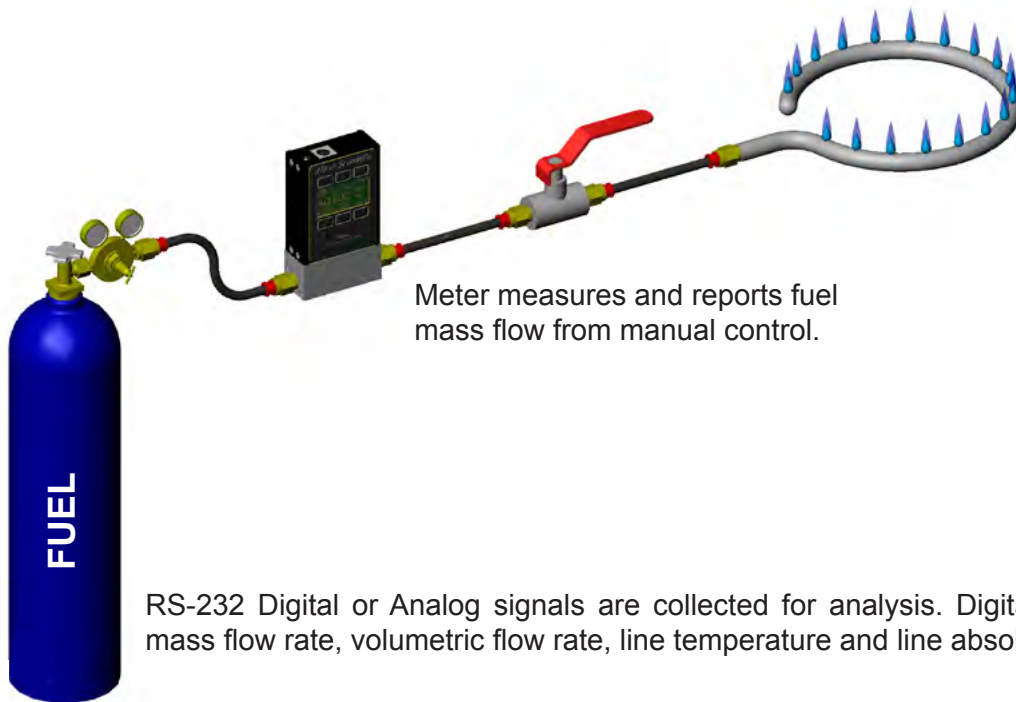

RS-232 Digital or Analog signals are collected for analysis. Digital signal includes mass flow rate, volumetric flow rate, line temperature and line absolute pressure.

COMMON APPLICATIONS

Real-time Appliance Development

10 millisecond metering time of flow, pressure and temperature simplifies the development process

Size Checking

Ensure that your appliance orifices are correctly sized by monitoring flow changes

Reliability Testing:

With **Accuracy, Repeatability** and **Streaming Data Acquisition**, you can verify that your gas flow remains constant

TIG (Tungsten Inert Gas) Welding

In the TIG (tungsten inert gas) welding process, a tungsten electrode is used to provide an electric arc for welding. A sheath of inert gas surrounds the electrode, the arc and the area to be welded. This gas shielding process prevents any oxidization of the weld and allows for the production of neat, clean welds.

TIG welding differs from MIG (metal inert gas) welding in that the electrode is not consumed in the weld. TIG welding is the preferred method for welding aluminum.

The shielding gas used in TIG welding can be argon, helium or a mixture. Argon is usually a better choice because it is heavier than air and therefore tends to provide a better blanket over the weld.

The flow from the gas supply is controlled by the Mass Flow Controller (MC-20SLPM-D) which is connected to the top of the tank.

The flow rate of the shielding gas varies by the material being welded. Aluminum requires 7-13 SLPM of Argon, while Stainless Steel requires 5-7 SLPM of Argon.

Popular gas blends for welding applications, such as Praxair's Helistar A1025[®] and Stargon CS[®], are included as selections in Alicat's Gas SelectTM feature.

In addition, Alicat's MFC's are highly resistant to electrical noise and other disturbances present in TIG welding environments.

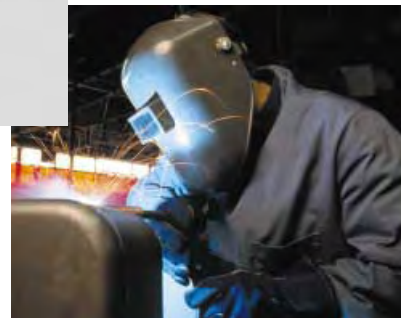
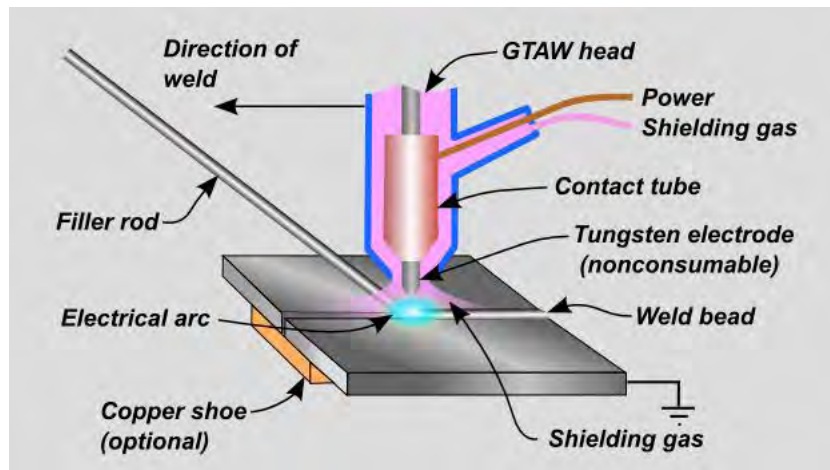

Reliable Air Delivery for Automated Liquid Paint Application

Robotic painting, one of the sectors within the Coatings Industry, has several applications in which mass flow is critical to paint application and control. In a typical application, paint is dispensed at the end of a robotic painting arm that articulates close to the surface, following the contours of the paint target (e.g. truck or car bodies). Spinning bells and pressurized guns are the final step in dispensing of the paint.

The liquid paint is atomized using a jet of air. The ratio of air to paint affects the atomization of the spray pattern, its consistency in application and the overall finish. The control of shaping air is critical to control of the pattern.

Maintaining accurate, repeatable and fast response control over the air flow is essential to the overall paint job quality and minimizing over painting, thereby reducing costs on every part painted.

Alicat Scientific has products both for use in automated paint applications and as field tools when installing or trouble shooting an existing system.

The multiple parameter outputs of Alicat instruments, either via RS-232 or secondary analog, are available for integration into the PLC operating parameters. This information can be used within the PLC to provide additional functions and to eliminate the cost of additional components.

For example, monitoring line pressure can be critical to proper operation of the robots and for an early indication of a failure in the delivery system. The Alicat mass flow meter's pressure signal eliminates the cost and maintenance of a separate pressure gauge.

To further facilitate the use of these units as a replacement component, they may also be configured to provide a secondary parameter via an independent, digital or analog output signal.

The most popular models for this use are:

M Series Meters: Guns: M-250SLPM-D-I /5CM
M-500SLPM-D-I /5CM
Bells: M-500SLPM-D-I /5CM
M-1000SLPM-D-I /5CM

MCR Series Controllers: MCR-250SLPM-D-I /5CIN
MCR-1000SLPM-D-I /5CIN



Bioreactor Outgassing

Research projects involving isolated chambers with decomposing organic components often use rotometers. The gas is released from the chamber and metered into a gas analyzer to determine the actual gas constituents.

The diagram demonstrates how an Alicat micro-flow mass meter (MFM) can be used instead of a rotometer to gain substantial improvements in device accuracy and automation. The Alicat MFM is set for methane gas calibration. The MFM reports the totalized gas flow to the PC, which incorporates this data with the analyzer's calculations.

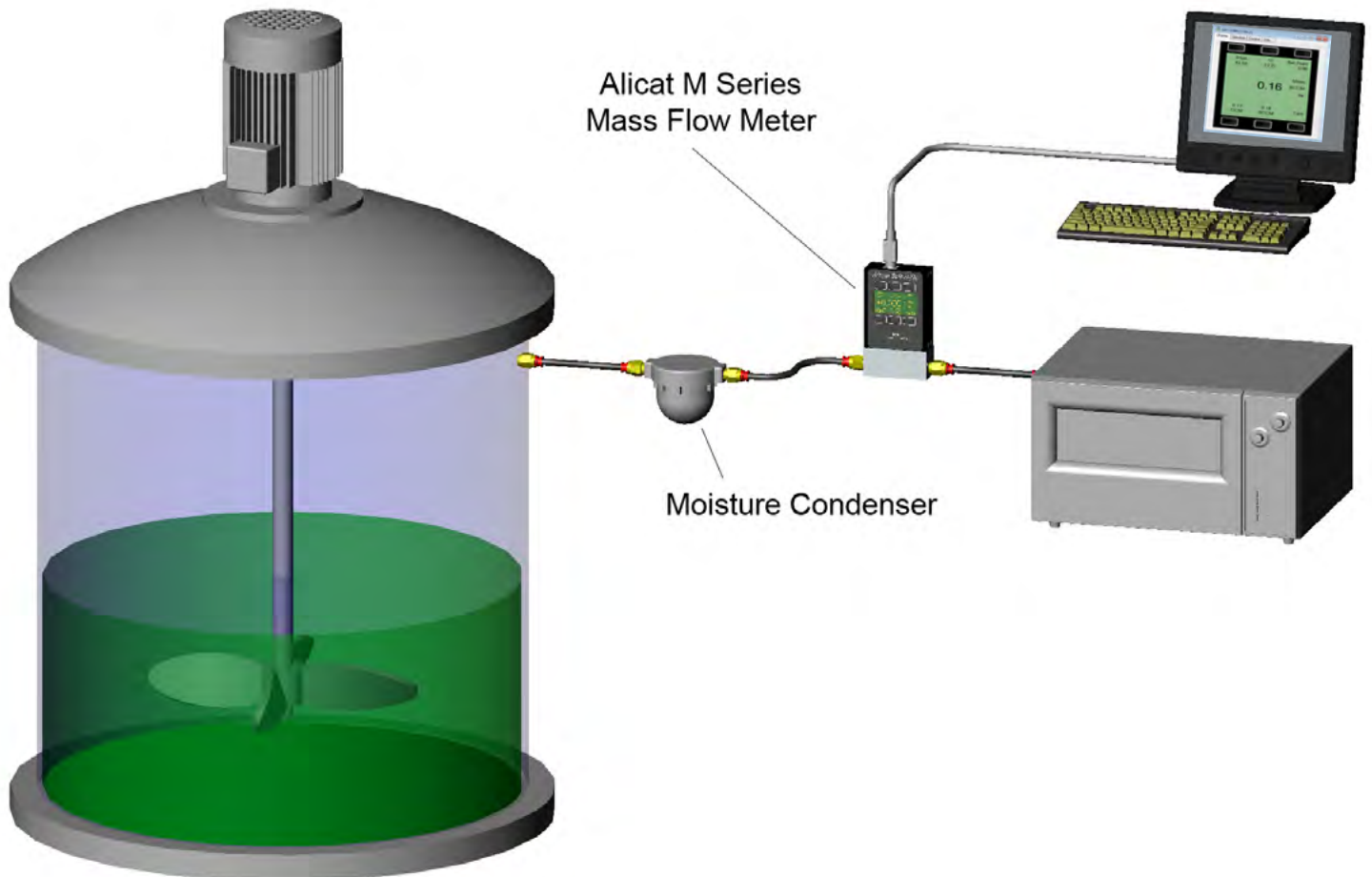

The actual gas being released from the chamber is not pure methane, but a number of gases mixed with methane. Viscosity calculations have indicated that the total flow accuracy will not exceed $\pm 2\%$ full scale. The MFM's high operating range of $\frac{1}{2}\%$ – 100% and digital communication ability, results in a test solution that is highly repeatable with simplified data collection

Product Sparging

Sparging is a process where a gas is injected into a liquid to achieve a variety of results. The sparging bar has many fine holes through which the gas is transferred into the product in the sparging tank.

Maintaining a constant flow rate is crucial in order to obtain the desired results. A mass flow controller can insure a constant flow rate as the level of product changes or the sparging bar becomes clogged, allowing a high level of quality to be maintained.

Sparging is done with many different gases:

- Air (to increase volume)
- Nitrogen (to remove water)
- Carbon Dioxide (to carbonate or decrease Ph)
- Hydrogen (to hydrogenate)
- Oxygen (to oxidize)

Alicat's MC Series Mass Flow Controllers are highly suitable for each of these purposes. The MCs provide local control and read out or they can interface directly with recording or control hardware via RS-232.

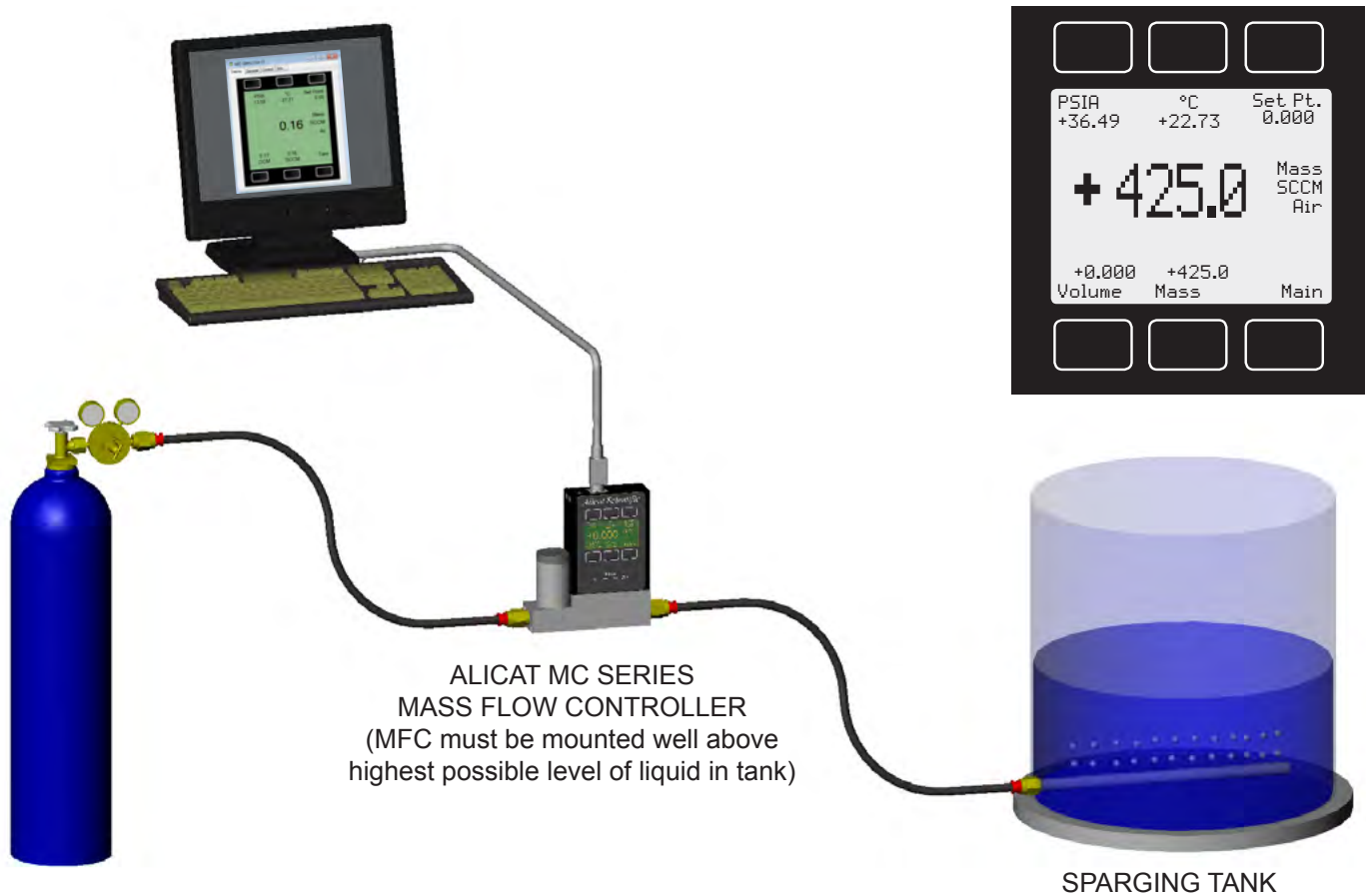

Simultaneously control flow and monitor sparging pressure to reveal clogging or abnormal fluid levels.

Fluid Dispensing Using Pressure Control

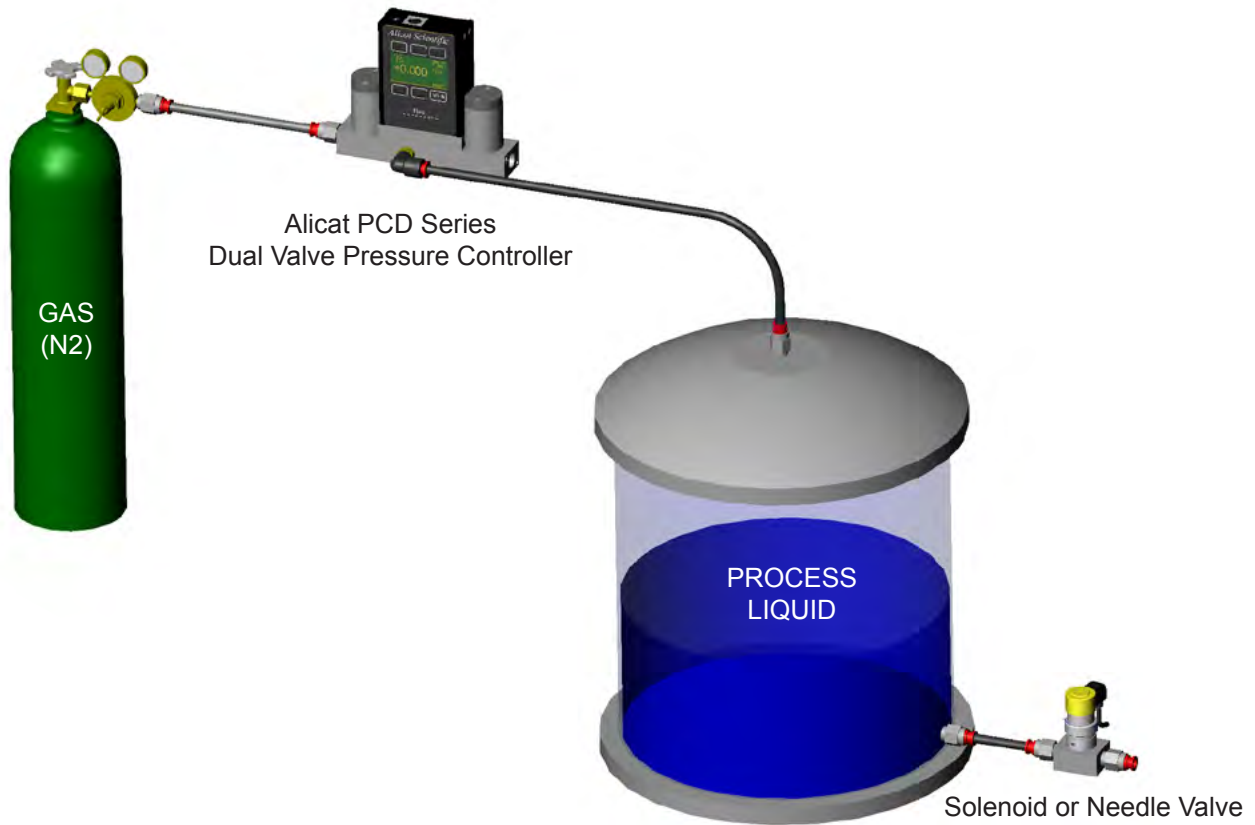

In this application, precise control of delivery of a fluid is accomplished through control of the head pressure on a liquid chamber using an Alicat Dual Valve Pressure Controller.

Typically, Nitrogen is used as the process gas and is vented to atmosphere through the downstream valve of the PCD. The pressure applied to the liquid allows for precision dispensing through activation of a solenoid or needle valve. Stability as high as 1 part in 5000 (.02% of FS) can be attained.

With Alicat's "RAM only" option, users can continually increase the head pressure in the chamber as the fluid level is decreasing. With processing times in the 400 microsecond range, very precise pressure changes can be applied.

This process is often used in silicon wafer polishing systems for the semiconductor industry as well as in some biotech applications.



PCD Series

Mixed Gas Re-Metering

Some production processes gain substantial quality and yield improvements through mixed gas re-metering. Historically, there have been few technologies that can support mixed gas re-metering, particularly in flows below 20SLPM or operating at low pressures. One solution uses Alicat's mass flow meters in combination with the Wilke Semi-empirical method for mixed gas viscosity calculations.

Mixed gas re-metering is different from a gas mixture calibration. In gas mixture calibrations sufficient accuracies ($\pm 1\%$ f.s.) can be obtained by using the actual gas mix in the calibration. In mixed gas re-metering the actual gas mixture is constantly changing as part of the production process.

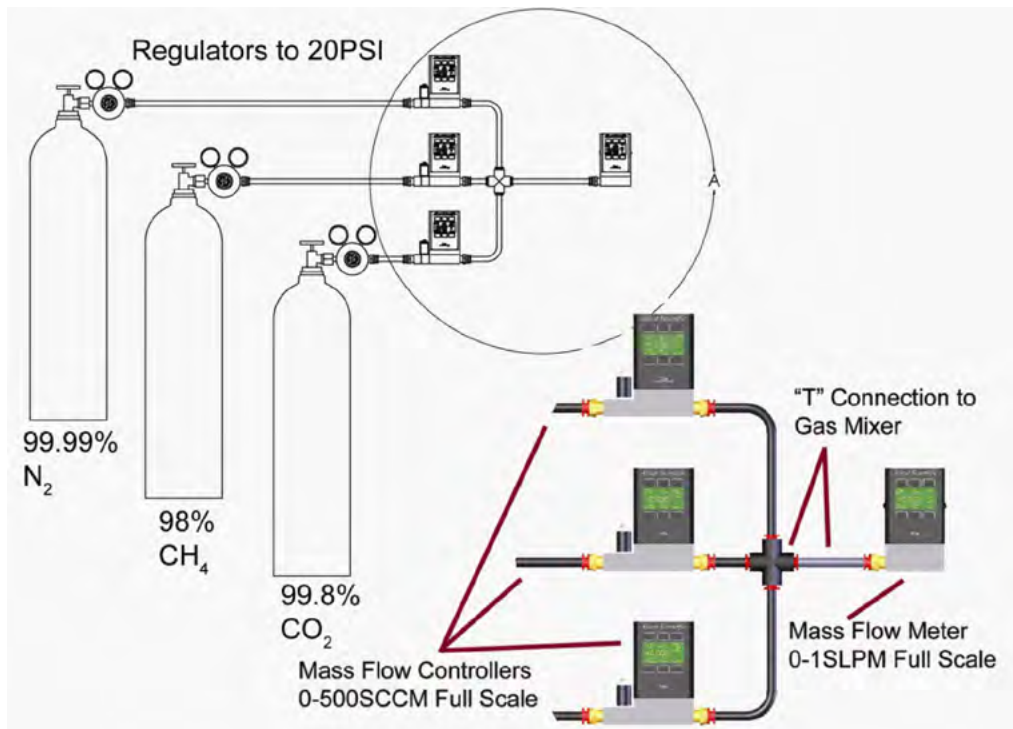

The diagram demonstrates three mass flow controllers (MFCs) regulating gases from individual tanks into a simple mixing tube. Next a mass flow meter (MFM) re-meters the gas mix. Each MFC has been set to the appropriate pure gas calibration using the gas select screen. The MFCs are receiving their fluctuating flow control ratios by the PC. The MFM is set for N₂ as a calibration reference point. The PC reads the MFM's indicated flow and performs some simple ratio corrections to determine the actual gas flow for the mixture.

To perform the ratio corrections, the PC uses the MFC's set-points to determine the percent of each gas in the resulting mixture. Next, the computer calculates the theoretical gas mixture viscosity using Wilke's equation. Finally, the PC determines the actual gas flow by performing a simple viscosity ratio correction on the indicated flow:

Actual Flow = Indicated Flow at N₂ Viscosity / Calculated Mix Viscosity

Laboratory tests have demonstrated an overall $\pm 3\%$ of reading accuracy for this technique. The engineers at Alicat Scientific have spreadsheets with the appropriate Wilke's calculations and viscosity look-up tables to simplify incorporating this method into an existing field PC. It should be noted that Wilke's method works best on gases operating below 125PSIG and 50°Celsius. It is possible to use methods other than the Wilke's equation for a re-metering system. If incorporating Alicat's mass flow devices it is crucial that the alternate mathematical model solves for viscosity, not thermal coefficients.

Approximate Weights









For approximate shipping weight add 0.2lb to each unit for packaging.

Description	Weight	Description	Weight
M Series Meters		LC & LCR Series Controllers	
0.5SCCM to 50SCCM	0.8lb	50CCM to 500CCM	1.2lb
100SCCM to 20SLPM	1.0lb	1LPM to 5LPM	6.8lb.
50SLPM	2.2lb	P Series Gauges	
100SLPM	2.4lb	All Standard Ranges	1.0lb
250SLPM	3.2lb	PC Series Controllers	
500SLPM to 1500SLPM	3.5lb	All Standard Ranges	1.2lb
2000SLPM to 3000SLPM	4.5lb	PCR Series Controllers	
MC & MCR Series Controllers		All Standard Ranges	4.8lb
0.5SCCM to 50SCCM	1.1lb	PCD Series Controllers	
100SCCM to 20SLPM	1.2lb	All Standard Ranges	1.4lb
50SLPM	6.4lb	Accessories	
100SLPM	6.4lb	universal power supply PVPS24U	1.8lb
250SLPM	8.3lb	Cables DC-61, DC-62, DC-6RT	0.2lb
500SLPM to 1500SLPM	9.0lb	Cables DC-251, DC-252	0.6lb
2000SLPM to 3000SLPM	11.0lb	Cable MD8DB9	0.1lb
MCV Controllers	3.0lb	Industrial Connector Cable IC10	0.2lb
L Series Meters		BB-9 Multi-Drop Box	1.0lb
0.5CCM to 1CCM	1.0lb	Flow Vision™ SC	0.4lb
2CCM to 1LPM	1.3lb		
2LPM to 10LPM	2.2lb		

Alicat Instruments— Simply the Most Standard Features

- ▶ Four instruments for the price of one! Mass flow, Volumetric flow, Pressure & Temperature.
- ▶ Control pressure while monitoring mass flow!
- ▶ Fast: ≤ 100 millisecond control response (typical). ▶ Accurate.
- ▶ No warm-up delays. ▶ Stand-Alone control.
- ▶ Gas Select™ with 30 field selectable gases, No charts to reference.
- ▶ RS-232 & Analog Input/Output. ▶ Multiple drop capable RS-232.
- ▶ Simple, position insensitive installation. ▶ No straight runs of pipe required!
- ▶ Low sensitivity to ambient pressure and temperature changes.
- ▶ Easy integration and bench top versatility.
- ▶ Support a wide range of options without extra software or components.

ALICAT SCIENTIFIC DOMESTIC DISTRIBUTORS

COMPANY		STATES and ZIP CODES	TELEPHONE	WEB SITE E-MAIL
	Clipper Controls Inc. 330 Townsend St. #107 San Francisco, CA 94107	CA (932, 936-961), HI, NV (892-899)	415-808-2469	www.clippercontrols.com ahoy@clippercontrols.com
	D&D Engineering 19355 Business Ctr Dr #2 Northridge, CA 91324	CA (900-931, 933-935), NV (889-891)	888-333-6474	www.sensorguys.com sales@sensorguys.com
	Finn and Conway 9221 Lanewood Ct Maple Grove MN 55369	IA, IL (620-622, 628-629), MN, MO, ND, SD, WI (540, 546-548)	763-496-1637	www.finnandconway.com john_knight@finnandconway.com
	Glatte Inc. 7150 Hart St, A1 Mentor OH 44060	IN (460-462, 467-479), KY, OH, PA (150-167), WV	440-266-1681	www.glatteinc.com mluck@glatteinc.com
	J.F. Hurlbut Co. 622 Gardenia Ct Golden, CO 80401 5	CO, MT, UT, WY	303-279-7796	www.jfhurlbut.com dfh@jfh.com
	King/Gage Engineering One Emerson Street Mendon, MA 01756	CT, MA, ME, NH, NY (120-149), RI, VT	508-482-0033	www.kinggageengineering.com chris@kinggageengineering.com
	Pascal Technologies Inc. 11905 Bowman Drive, Suite 101B Fredericksburg, VA 22408	DC, DE, MD, NJ, NY (100-119), PA (168-196), TN, VA AL, FL, MS, NC, SC	800-367-2919	www.pascaltechnologies.com rwilson@pascaltechnologies.com
	Progressive Instruments 2326 Campbell Road, Bldg. B Houston, TX 77080	TX	866-350-1351	www.progressiveinstruments.com rdarsey@progressiveinstruments.com
	Thermo/Cense, Inc. 533 Capital Dr Lake Zurich, IL 60047	IL (600-619, 623-627), IN (463-466), WI (530-539, 541-545)	800-646-8070	www.thermocense.com sales@thermocense.com

ALICAT SCIENTIFIC INTERNATIONAL DISTRIBUTORS

COMPANY		COUNTRY	TELEPHONE	WEB SITE E-MAIL
	Duff and MacIntosh Pty. Ltd. 13/45 Leighton Place, Hornsby, NSW 2077 Australia	AUSTRALIA	(02) 9482 1411	www.duffmac.com.au sales@duffmac.com.au
	TecnoVip Rua Sao Paulo, 467 - Sala A Vila Santana Valinhos, SP 13274-115 Brazil	BRAZIL	(19) 3859-9459	www.tecnovip.com tecnico@tecnovip.com
	Alpha Controls & Instrumentation 361 Steelcase Road West Suite 6 Markham, Ontario L3R 3V8 Canada	CANADA (Eastern)	905-477-2133	www.alphacontrols.com jerry@alphacontrols.com
	Muis Controls Ltd. 29 Riel Drive St. Albert, Alberta T8N 3Z2 Canada	CANADA (Western)	1-800-661-8823	www.muiscontrols.com info@muiscontrols.com
	Beijing Longradar Technology & Trading Co. Ltd Room 901, JinJiYe Building #2 ShengGu Middle Road, ChoaYang, Beijing 100029 China	CHINA	+86 10 64449938	www.longradar.com.cn sales@longradar.com.cn
	SciTech, spol. s.r.o. Nad Sarkou 75, CZ-160 00 Praha 6 Czech Republic	CZECH REPUBLIC SLOVAKIA, HUNGARY, POLAND	+420 224 311 850	www.scitech.cz drasar@scitech.cz
	Kubler Suomi Oy Kelatie 25 A 1-3 Vantaa 01450 Finland	FINLAND	(09) 8700 960	www.kubler.fi kubler@kubler.fi
	System C Instrumentation Allee de Chamille - ZI Bois des Lots BP 38 St Paul Trois Chateaux Cedex 26131 France	FRANCE NORTH AFRICA	04 75 54 86 00	www.system-c-industrie.com assistance@system-c-industrie.com
	NATEC Sensors GmbH Niels-Bohr-Strasse 9-11 85748 Garching Germany	GERMANY, AUSTRIA, SWITZERLAND	+49 89 307 591 0	www.natec-sensors.com sales@natec-sensors.com

continued on following page

ALICAT SCIENTIFIC INTERNATIONAL DISTRIBUTORS CONTINUED

COMPANY	COUNTRY	TELEPHONE	WEB SITE E-MAIL
 <p>Aeronics eMaROH Sathish Kumar # 782, 7th Cross Muthyalanagar, MES Road Bangalore - 560 054 India</p>	INDIA	+91 80 23459590	www.aeronics.in venkat@aeronics.in
 <p>Carl Stuart Limited Tallaght Business Park Whitestown Dublin, 24 Ireland</p>	IRELAND	353 1 4523432	www.carlstuart.com kevin.arthure@carlstuart.com
 <p>Emproco, Ltd Southern Industrial Estate, POB 730 Ashkelon 78107 Israel</p>	ISRAEL	972-(0)8-6718187	www.emproco.com info@emproco.com
 <p>Comhas Srl Via Matteotti, 66 Cinisello Balsamo (Milano), 20092 Italy</p>	ITALY	+39 02 61298551	www.ComHas.com riccardo@comhas.com
 <p>isonik, Corporation 9-1-405 Namiki 2 cho Kanazawa-Ku Yokohama 236-005 Japan</p>	JAPAN		isonik@herb.ocn.ne.jp
 <p>V.O.F. Inacom Instruments Dwarsweg 71a 3959 AE Overburg Netherlands</p>	NETHERLANDS	(0318) 52 11 51	www.inacom.nl info@inacom.nl
 <p>Instrumatics Suite 2, 19 Beasley Ave Penrose, Otahuhu Auckland New Zealand</p>	NEW ZEALAND	+64 (0)9 526 0096	www.instrumatics.co.nz helpdesk@instrumatics.co.nz
 <p>Paralab Tv. do Calvário, 65 Giesta, Valbom, Gondomar 4420-392 Portugal</p>	PORTUGAL	+351 22 466 43 20	luisa.cruz@paralab.pt
 <p>Actan Verhoyanskaya str, 18/2 Moscow, 129344 Russia</p>	RUSSIA	+7 495 228-09-75	www.actan.ru s.simanchov@actan.ru
 <p>Semiconductor Technologies Singapore Pte Ltd No. 18 Sin Ming Lane #05-01 Midview City Singapore 573960</p>	SINGAPORE, THAILAND, VIETNAM, INDONESIA, PHILIPPINES	65 6459 5962	www.semicontechnologies.com pillai@semicontechnologies.com
 <p>Royce Water Systems 8th Floor, Everite House 20 de Korte Street Braamfontein, Johannesburg 2001 South Africa</p>	SOUTH AFRICA	+27 11 403-2247	www.aisa.co.za support@aisa.co.za
 <p>Top Control Corp. Room 1014, Hongin Officetel 536-9 Bongmyung-Dong, Yusung-Ku Taejeon 305-710 South Korea</p>	SOUTH KOREA	+82 42 828 7001	sung2207@yahoo.com
 <p>Iberlabo, SA C/. Tellez, 30 Local 17 Madrid 28007 Spain</p>	SPAIN	91 551 1491	www.iberlabosa.com davidb@iberlabosa.com
 <p>Kompauto Nordic AB Box 265 Ludvika 771 26 Sweden</p>	NORWAY, DENMARK, SWEDEN	+46(0)240 150 09	www.kompauto.se info@kompauto.se
 <p>Sinom Corporation No. 33, Sec. 4, Jhongsing Road Dist. WuGu, New Taipei City Taiwan, ROC 24873</p>	TAIWAN	886-2-22920001	www.sinom.com.tw support@sinom.com.tw
 <p>Premier Control Technologies Ltd Suite 1, Trident Business Park Kilverstone Estate Theftord, Norfolk IP24 1RL United Kingdom</p>	UNITED KINGDOM	+44 (0) 1842 753 456	www.pctflow.com christaylor@pctflow.com

We want your input!

***If you have any suggestions, ideas or concerns regarding any Alicat product —
Please contact us at: feedback@alicatescientific.com.***

Have You Considered Cost of Ownership?

Before you make any purchases, you need to consider the cost of ownership along with the cost of the product itself.

If MFCs from two different manufacturers have similar technological attributes, you might just decide to purchase the less expensive of the two — but is that always the right choice? How long do you expect to use the product? How much support will it require to maintain? You need to consider the whole package in order to make the right decision.

Alicat products are affordable with quick delivery—2 weeks or less.

We provide excellent technical support, low cost recalibration and short turnaround, with repairs usually shipped within 3-5 days of receipt.

Combine that with unparalleled standard features, an extensive list of options and the industry's first lifetime warranty and you have an impressive package!

Call Alicat today. We'll help you choose the device that is right for you.



ALICAT SCIENTIFIC, INC.'S WIDE-RANGE LAMINAR FLOW ELEMENT PATENT:

The wide-range laminar flow element and products using the wide-range laminar flow element are covered by U.S. Patent Number: 5,511,416. Manufacture or use of the wide-range laminar flow element in products other than Alicat Scientific products or other products licensed under such patents will be deemed an infringement.

All Alicat instruments are supplied with NIST traceable certification.

Alicat products in compliance with the requirements of the Low Voltage Directive 73/23/EEC and the EMC Directive 89/336/EEC (including 93/68/EEC) carry the CE Mark.

FIND YOUR FLOW AND PRESSURE SOLUTIONS AT ALICAT™ TODAY!



7641 N Business Park Drive
Tucson, Arizona 85743, USA

Phone: 520-290-6060 | 888-290-6060

Fax: 520-290-0109

alicatscientific.com