

SECTION A-A

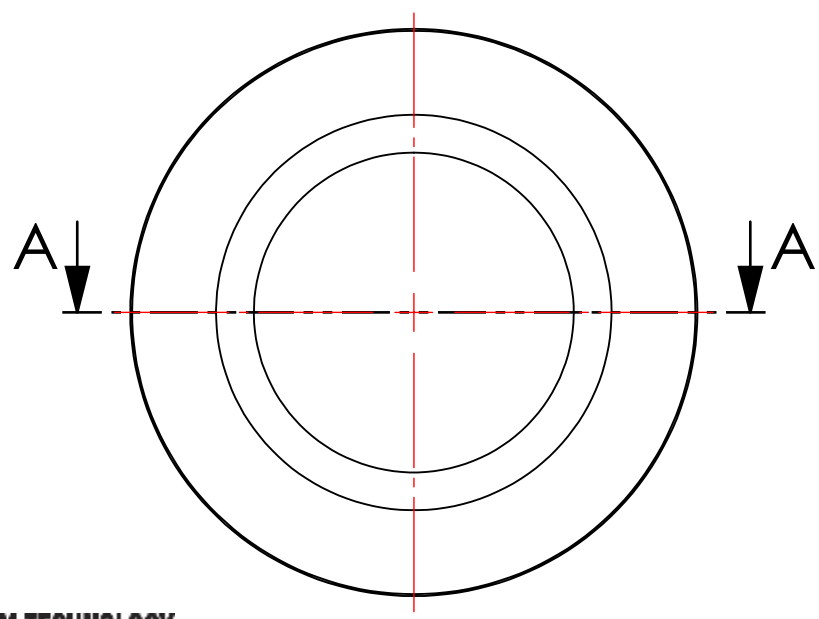

UNLESS OTHERWISE SPECIFIED:
 DIMENSIONS ARE IN MILLIMETERS
 SURFACE FINISH:
 TOLERANCES: ISO 2768-fk
 LINEAR:
 ANGULAR:

FINISH: Machined Ra 1.6

DEBUR AND
 BREAK SHARP
 EDGES

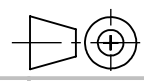

DO NOT SCALE DRAWING

REVISION

Hositrad Holland B.V.

	NAME	SIGNATURE	DATE		
DRAWN	S.A. Pul				
CHK'D					
APPV'D					
MFG					
Q.A					
				MATERIAL:	
				SST304 / 1.4301	
				WEIGHT:	

TITLE:	KF50 Blind Flange	
	A1122XXXX - 22XXXX - 20220XXX	
DWG NO.	KF50-B	A4
SCALE:1:1	SHEET 1 OF 1	